

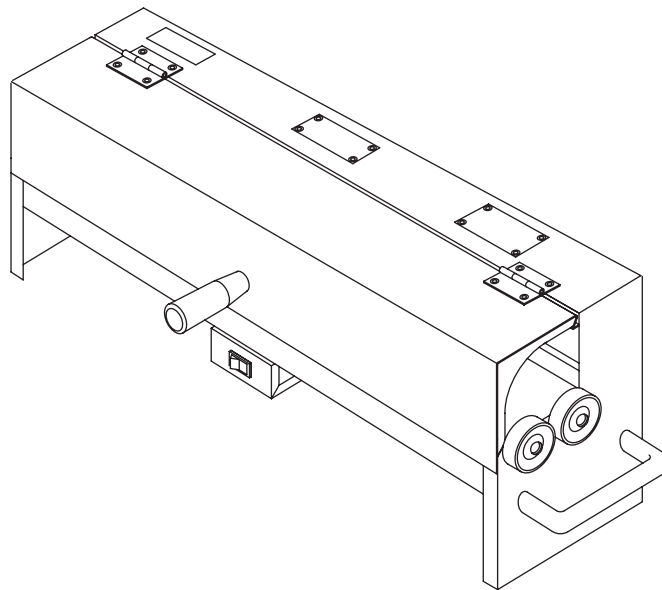

Current Tools

FOR THE PROFESSIONAL ELECTRICIAN

Current Tools™ Model 450 1/2" to 2" PVC Heater



Operating, Maintenance, Safety and Parts Manual

07/11 - REV. 3



Read and understand this material before operating the PVC Heater. Failure to understand how to safely operate and service this unit may result in serious injury or death.

This manual is free of charge. All personnel who operate or service the PVC Heater should have a copy of this manual and read and understand its contents. To request a copy, call or write to the address below.

**CURRENT TOOLS • P. O. BOX 17026 GREENVILLE, SC 29606
800.230.5421 or 864-721-4230 • FAX 864-721-4232
www.currenttools.com**

RETAIN SAFETY INFORMATION



This manual should be read and understood by all personnel who operate or service this PVC heater. Failure to understand how to safely operate and service this unit could result in injury or death. This unit should only be operated by qualified personnel.

IMPORTANT SAFETY INFORMATION

- ALWAYS wear hand protection when operating this equipment and when bending PVC conduit. Use handle to open and close the PVC heater door.
- DO NOT use in wet conditions. DO NOT expose to rain or moisture.
- DO NOT use near flammable materials.
- DO NOT leave PVC heater unattended.
- Turn PVC heater off when not in use.
- Use for heating PVC conduit only. DO NOT use for any other purpose.
- Use only for PVC conduit sizes specified.
- Operate only in a well ventilated area.

The electric plug on this PVC heater includes a grounding conductor as shown. Do NOT modify the plug. Only connect the unit to a 15 AMP GFCI protected receptacle which is properly installed and grounded to meet all applicable electrical codes.

WARNING

ELECTRIC SHOCK HAZARD! Only connect this PVC Heater to a 15 AMP GFCI protected circuit. Do NOT modify the plug which is provided with the unit. Failure to follow these warnings can result in serious injury or death.



PLUG

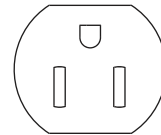

RECEPTACLE

SPECIFICATIONS — 450 PVC Heater

Model No.	— 450
Capacity	— 1/2" to 2" PVC conduit
Power	— 115 volts AC, 15 amps, 60 hz, 1700 watts
Dimensions	— 6 3/4" x 7 5/8" x 26 1/2"
Weight	— 20 lbs.

MATERIALS NEEDED

- Sponge or clean cloth
- Bucket with clean water
- Insulated gloves

OPERATING INSTRUCTIONS — 450 PVC Heater

1. Place PVC conduit heater on a flat, dry surface. Plug heater into GFCI protected receptacle. Turn switch to ON position. Switch will illuminate when unit is ON.
2. Put on insulated gloves.
3. After warm-up period, (approximately 10 min.) place conduit on rollers inside unit and close door using handle.
4. Slowly rotate conduit by hand until pliable. To test, lift one end of the PVC conduit. Conduit is ready when it has a glossy appearance and bends when lifted.

NOTE: PVC conduit MUST be rotated to provide even heating and to prevent scorching.

NOTE: PVC conduit will take approximately 30 seconds to heat for each ½" of PVC conduit diameter. (Example: 2" PVC conduit will heat in approximately 2 minutes.)

5. Open the heater door using the handle and remove conduit from heater and place on a clean, flat surface. Hand bend to desired angle. The bend can be set by allowing to air cool or decrease this time by rubbing the bend with a sponge soaked in cool water. NOTE: Be sure to keep all liquids away from the PVC heater and turn unit off when not in use.

PVC CONDUIT HEATER ACCESSORIES

- To prevent flattening and crimping during the bending process, Current Tools *plug sets* are recommended for 2" and larger PVC conduit.

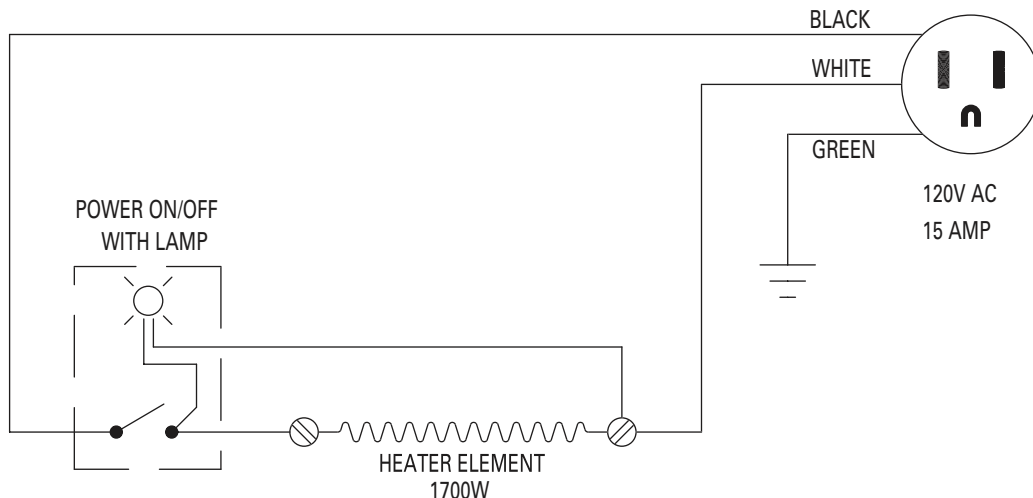

WIRING SCHEMATIC

EXPLODED VIEW

450 PVC HEATER

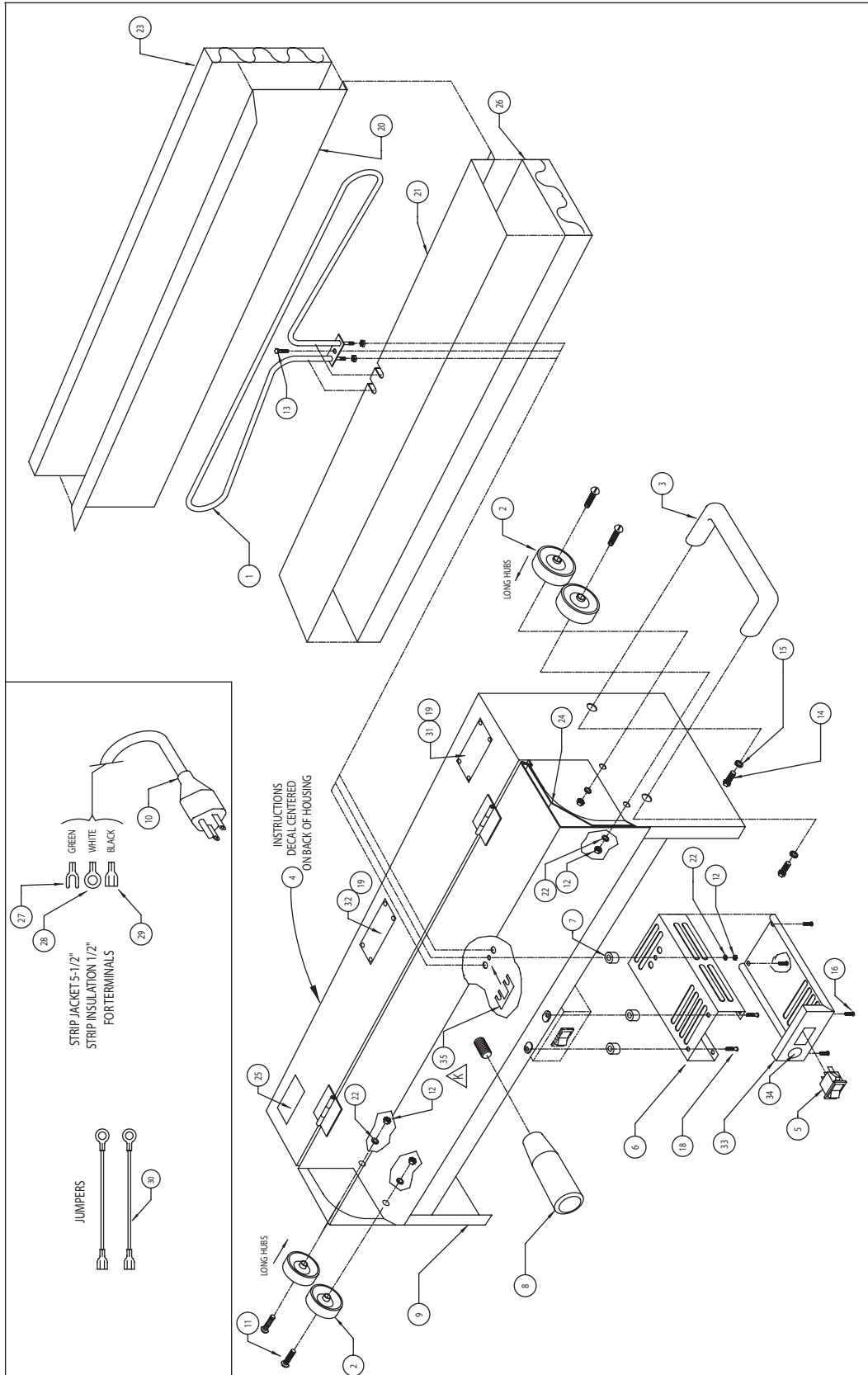

PARTS LIST — 450 PVC Heater

ITEM#	PART #	QTY	DESCRIPTION
1	450-1	1	HEATING ELEMENT
2	9500-530	4	SKATE WHEEL
3	450-11	1	LIFT HANDLE
4	450-35	1	DECAL – REAR INSTRUCTION (NOT SHOWN)
5	450-6	1	LIGHTED SWITCH
6	450-007	1	ELECTRICAL BOX
7	450-20	3	SPACER
8	450-12	1	DOOR HANDLE
9	450-015	1	MAIN HOUSING
10	450-4	1	POWER CORD
11	450-29	4	SLOTTED MACH. SCREW ¼-20 X 1 ¼"
12	450-14C	5	¼-20 HEX NUT
13	450-1A	1	HEX HD CAP SCREW ¼-20 X ¾"
14	450-11A	2	HEX HD CAP SCREW M8 X 12
15	450-11B	2	M8 LOCK WASHER
16	451-22	4	SLOTTED MACH. SCREW 10-32 X ¾"
17	450-18	1	STRAIN RELIEF (NOT SHOWN)
18	452-6D	2	SLOTTED MACH. SCREW 10-32 X ¾"
19	450-44A	8	RIVET – 1/8 SS X .06-.13 GRIP LENGTH
20	450-005	1	UPPER SHIELD
21	450-006	1	LOWER SHIELD
22	450-14G	5	¼" LOCK WASHER
23	450-16A	1	INSULATION-1" THICK (8"W X 26"L)
24	450-128	1	DOOR SHIELD
25	450-34A	1	DECAL, WARNING
26	450-9A	1	INSULATION-2" THICK (5½"W X 26"L)
27	452-19B1	1	FORK TERMINAL
28	451-29	1	RING CONNECTOR
29	451-30	1	FEMAL DISCONNECT
30	450-718	2	WIRE – HEAT RES.
31	450-36	1	PLATE, SERIAL NUMBER
32	450-34	1	PLATE, CAUTION HOT
33	450-391	1	COVER – ELEC. BOX
34	450-34C	1	DECAL, NO WATER
35	450-744	1	SPACER

NOTE: Prior to 08/06 - REV. 1, skate wheels were mounted inside the unit.