

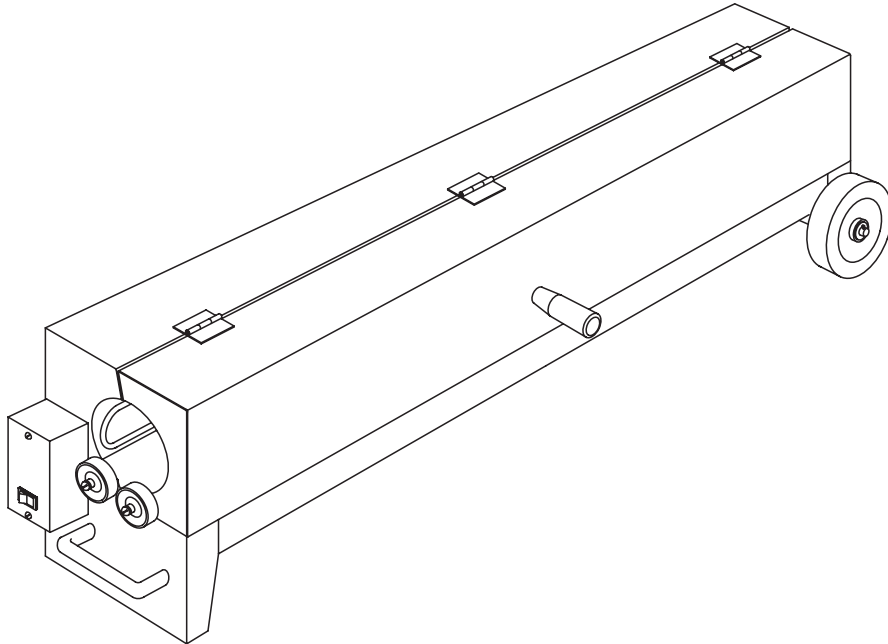

Current Tools

FOR THE PROFESSIONAL ELECTRICIAN

Current Tools™ Model 451 — ½" to 4" PVC Heater



Operating, Maintenance, Safety and Parts Manual

08/11 REV. 3



Read and understand this material before operating or servicing the PVC Heater. Failure to understand how to safely operate and service this unit could result in serious injury or death.

This manual is free of charge. All personnel who operate the PVC Heater should have a copy of this manual and read and understand its contents. To request a copy, call or write to the address below.

**CURRENT TOOLS • P. O. BOX 17026 GREENVILLE, SC 29606
800.230.5421 or 864-721-4230 • FAX 864-721-4232
www.currenttools.com**

RETAIN SAFETY INFORMATION



This manual should be read and understood by all personnel who operate or service the PVC Heater. Failure to understand how to safely operate and service this unit could result in injury or death. This unit should only be operated by qualified personnel.

IMPORTANT SAFETY INFORMATION

- ALWAYS wear hand protection when operating this equipment and when bending PVC conduit. Use handle to open and close the PVC heater door.
- DO NOT use in wet conditions. DO NOT expose to rain or moisture.
- DO NOT use near flammable materials.
- DO NOT leave PVC heater unattended.
- Turn PVC heater off when not in use.
- Use for heating PVC conduit only. DO NOT use for any other purpose.
- Use only for PVC conduit sizes specified.
- Operate only in a well ventilated area.

The electric plug on this PVC Heater includes a grounding conductor as shown. Do NOT modify the plug. Only connect the unit to a 20 AMP GFCI protected receptacle which is properly installed and grounded to meet all applicable electrical codes. Do NOT use an adapter.

⚠ WARNING ⚠

ELECTRIC SHOCK HAZARD! Only connect the PVC Heater to a 20 AMP GFCI protected circuit. Do NOT modify the plug which is provided with the unit. Failure to follow these warnings can result in serious injury or death.



PLUG

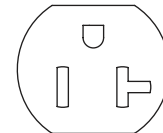

RECEPTACLE

SPECIFICATIONS — 451 PVC Heater

Model No.	—	451
Capacity	—	½" to 4" PVC conduit
Power	—	115 volts AC, 20 amps, 60 hz, 2300 watts
Dimensions	—	8 ⅝" x 12 ⅞" x 56"
Weight	—	50 lbs.

MATERIALS NEEDED

- Sponge or clean cloth
- Bucket with clean water
- Insulated gloves

OPERATING INSTRUCTIONS — 451 PVC Heater

1. Place PVC conduit heater on a flat, dry surface. Plug heater into GFCI protected receptacle. Turn switch to ON position. Switch will illuminate when unit is on.
2. Put on insulated gloves.
3. After warm-up period, (approximately 10 min.) place conduit on rollers inside unit and close door using handle.
4. Slowly rotate conduit by hand until pliable. To test, lift one end of the PVC conduit. Conduit is ready when it has a glossy appearance and bends when lifted.

NOTE: PVC conduit MUST be rotated to provide even heating and to prevent scorching.

NOTE: PVC conduit will take approximately 30 seconds to heat for each ½" of PVC conduit diameter. (Example: 2" PVC conduit will heat in approximately 2 minutes.)

5. Open the heater door using the handle and remove conduit from heater and place on a clean, flat surface. Hand bend to desired angle. The bend can be set by allowing to air cool or decrease this time by rubbing the bend with a sponge soaked in cool water. NOTE: Be sure to keep all liquids away from the PVC Heater and turn unit off when not in use.

PVC CONDUIT HEATER ACCESSORIES

- To prevent flattening and crimping during the bending process, Current Tools *plug sets* are recommended for 2" and larger PVC conduit.

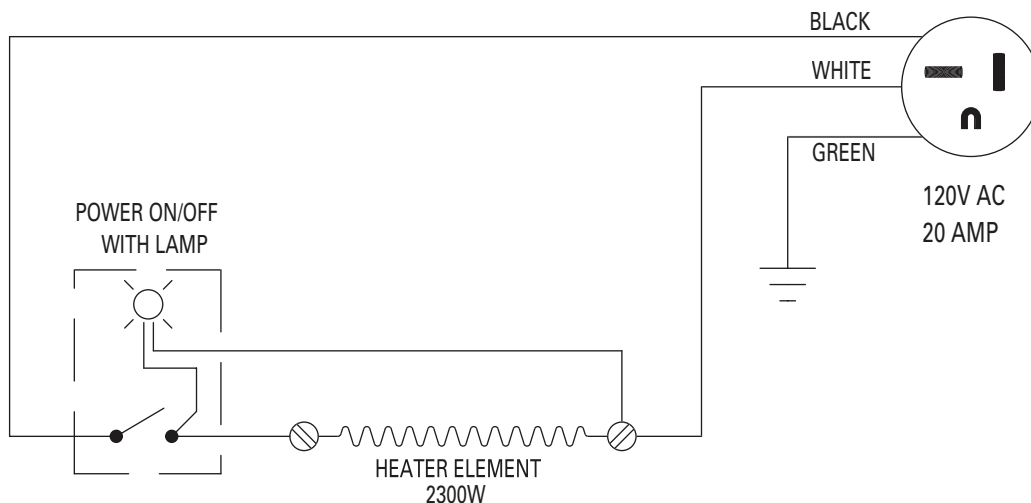

WIRING SCHEMATIC

EXPLODED VIEW

451 PVC HEATER

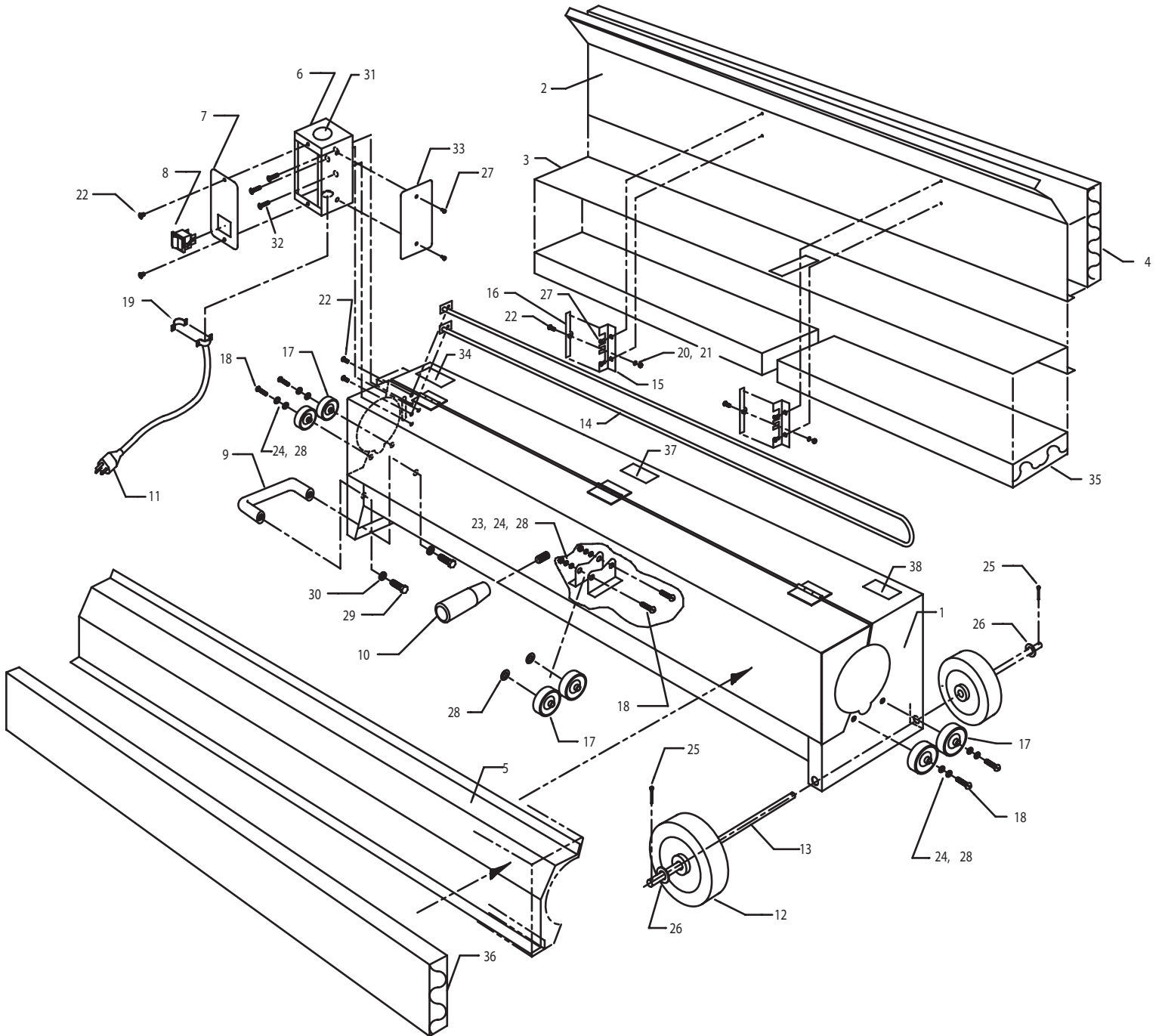

PARTS LIST — 451 PVC Heater

ITEM#	PART#	QTY	DESCRIPTION
1	451-014	1	HOUSING FAB (SEE BREAKDOWN)
2	451-157	1	BACK SHIELD
3	451-156	1	BOTTOM SHIELD
4	451-9A	1	INSULATION-2" THICK (10"W X 52"L)
5	451-158	1	DOOR SHIELD
6	451-112	1	ELECTRICAL BOX
7	451-391	1	COVER-ELECTRICAL BOX
8	451-19	1	SWITCH
9	450-11	1	PULL HANDLE
10	450-12	1	DOOR HANDLE
11	451-PWRCORD	1	POWER CORD
12	451-13	2	WHEEL
13	451-670	1	AXLE
14	451-057	1	ELEMENT
15	451-045	2	RETAINER BRACKET
16	451-045A	2	RETAINER CLIP
17	9500-530	6	SKATE WHEEL
18	450-29	6	SLT RD HD MACH. SCREW 1/4-20 X 1 1/4"
19	450-18	2	STRAIN RELIEF
20	450-14J	2	#10 FLAT WASHER
21	451-21	2	#10-32 HEX NUT
22	451-22	6	SLOTTED MACH. SCREW #10-32 X 3/8"
23	450-14C	2	1/4-20 HEX NUT
24	450-14G	6	1/4" LOCK WASHER
25	451-23	2	COTTER PIN (3/32" X 3/4")
26	451-25	2	1/2" FLAT WASHER
27	450-28A	6	RIVET-3/16 X 1/4 (SS)
28	450-14I	8	1/4" FLAT WASHER
29	450-11A	2	8 X 12 HEX HD. CAP SCREW
30	450-11B	2	M8 LOCK WASHER
31	450-34B	1	DECAL – NO WATER
32	452-6D	3	SLT RD HD MACH. SCREW 10-32 X 3/4"
33	451-126	1	HEAT SHIELD
34	450-34A	1	DECAL – DANGER
35	451-9B	2	INSULATION-2" THICK (7"W X 24"L)
36	451-16A	1	INSULATION-1" THICK (8 1/2"W X 52"L)
37	450-34	1	PLATE – CAUTION HOT
38	451-17	1	PLATE – SERIAL NUMBER
39	451-16	1	DECAL – OPERATING INSTRUCTIONS (NOT SHOWN)