

INSTRUCTION MANUAL

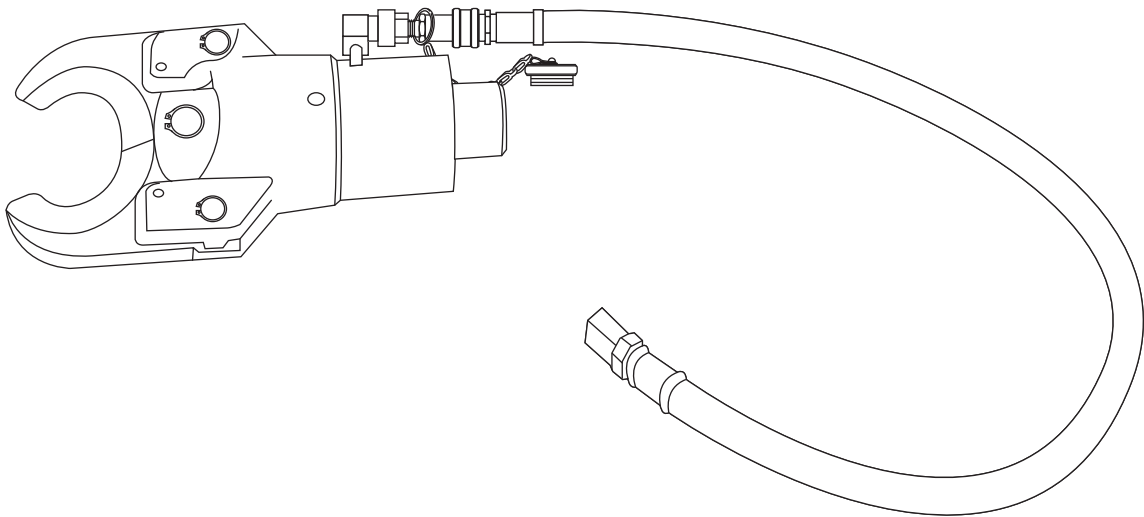

750 Cable Cutter



Read and understand all of the instructions and safety information in this manual before operating or servicing this tool.

Register this product at www.greenlee.com

Table of Contents

Description 2
 Safety 2
 Purpose of this Manual 2
 Important Safety Information 2-3
 Setup 4
 Operation..... 4
 Converting a 746 Hydraulic Ram
 to a 750 Cable Cutter 4
 Maintenance 5
 Illustrations 6-7
 Parts List 8

Description

The 750 Cable Cutter is a hydraulic cable cutter with hardened and precision-ground jaws designed to cut large cable.

The capacity of this tool is 1000 MCM standard copper or aluminum power cable and 1000 MCM underground million jacketed cable (260 mil/2.25 dia.)

Safety

Safety is essential in the use and maintenance of Greenlee tools and equipment. This instruction manual and any markings on the tool provide information for avoiding hazards and unsafe practices related to the use of this tool. Observe all of the safety information provided.

Purpose of this Manual

This instruction manual is intended to familiarize personnel with the safe operation and maintenance procedures for 750 Cable Cutter.

Keep this manual available to all personnel.

Replacement manuals are available upon request at no charge at www.greenlee.com.

All specifications are nominal and may change as design improvements occur. Greenlee Textron Inc. shall not be liable for damages resulting from misapplication or misuse of its products.

Loctite is a registered trademark of Loctite Corporation.

IMPORTANT SAFETY INFORMATION

SAFETY ALERT SYMBOL

This symbol is used to call your attention to hazards or unsafe practices which could result in an injury or property damage. The signal word, defined below, indicates the severity of the hazard. The message after the signal word provides information for preventing or avoiding the hazard.

⚠ DANGER

Immediate hazards which, if not avoided, **WILL** result in severe injury or death.

⚠ WARNING

Hazards which, if not avoided, **COULD** result in severe injury or death.

⚠ CAUTION

Hazards or unsafe practices which, if not avoided, **MAY** result in injury or property damage.



⚠ WARNING

Read and understand all of the instructions and safety information in this manual before operating or servicing this tool.

Failure to observe this warning could result in severe injury or death.

KEEP THIS MANUAL

IMPORTANT SAFETY INFORMATION

	⚠ WARNING
<p>Electric shock hazard: This tool is not insulated. Contact with live circuits could result in severe injury or death.</p>	

⚠ WARNING	
<ul style="list-style-type: none"> • Use only Greenlee-supplied hoses and couplers. • Do not cut cable under tension. • Follow instructions and safety information supplied with pump. <p>Failure to observe these warnings could result in severe injury or death.</p>	

	⚠ WARNING
<p>Skin injection hazard:</p> <ul style="list-style-type: none"> • Hand-tighten all couplers completely before operating the pump. All threads must be engaged. Do not use tools to tighten the couplers. • Do not use hands to check for leaks while operating the pump. • Do not hold hose or couplers while operating the pump. • Depressurize hydraulic system before disconnecting hoses or couplers, and before servicing. <p>Oil under pressure easily punctures skin causing serious injury, gangrene or death. If you are injured by escaping oil, seek medical attention immediately.</p>	

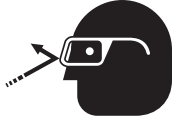
	⚠ WARNING
<p>Wear eye protection when operating or servicing this tool.</p> <p>Failure to wear eye protection could result in serious eye injury from flying debris or hydraulic oil.</p>	

	⚠ WARNING
<p>Keep hands away from cutting jaws.</p> <p>Failure to observe this warning could result in severe injury or death.</p>	

⚠ CAUTION	
<ul style="list-style-type: none"> • Inspect the cutter before use. Replace worn, damaged, or missing parts with Greenlee replacement parts. A damaged or improperly assembled component could break and strike nearby personnel. • Maintain tools with care. Keep tool clean for best and safest performance. Follow instructions for lubricating and changing accessories. <p>Failure to observe these precautions may result in injury or property damage.</p>	

Setup

Connect the high-pressure hydraulic hose to hydraulic pump.

Note: Clean the quick-change couplers before making connections. Hand-tighten the couplers until all threads are fully engaged. Do not use tools.

Operation

	⚠ WARNING
	<p>Electric shock hazard: This tool is not insulated. Contact with live circuits could result in severe injury or death.</p>

	⚠ WARNING
	<p>Keep hands away from cutting jaws. Failure to observe this warning could result in severe injury or death.</p>

- Place the cable to be cut between the jaws.
- Turn the pump knob to PUMP. Pump the lever until cable is cut completely.
Note: If using an electric pump, follow the instructions that came with the pump.
- To open the jaws, turn the pump knob to RELEASE.

Converting a Greenlee Model 746 Hydraulic Ram to a Greenlee Model 750 Cable Cutter

To use your Greenlee Model 746 Hydraulic Ram to cut cable, see the following instructions to combine the 746 with a Greenlee Model 751 Cutter Head Unit.

Assembly

- Remove the draw stud from the 746 ram unit.
- Insert the ram into the cutter head unit. Thread the 751's draw stud into the 746 ram.
- Turn the 746 clockwise until the jaw opening measures 2.25". See Figure 1.
- Tighten the set screw (30).
- Connect the 746 ram to any Greenlee pump, such as the following models:
 - 755 Hand Pump
 - 767 Hand Pump
 - 1725 Foot Pump
 - 975 Electric Pump
 - EHP700L Battery-powered Pump

Note: Use only Greenlee hoses and couplers. Use only Greenlee or Greenlee Utility model hydraulic pumps.

⚠ CAUTION
<p>Do not use hydraulic pumps that have a flow rate that exceeds 18 in³/min (0.32 L/min) at full pressure and exceeds a maximum pressure of 10,000 psi (700 bar). An excessive flow rate will close the cutting blades at a rate quicker than the tool was designed for and will reduce your time to react if an obstruction occurs.</p> <p>Failure to observe this precaution may result in injury or property damage.</p>

- Using the instructions supplied with the pump, advance the ram to close the cutter jaws.
- Check for a minimum blade overlap of 0.030" on centerline prior to the end of the ram stroke. See Figure 2.

Maintenance

Keep all parts clean and lubricated with a light coat of moly-filled grease. Periodically check the open jaw dimension (2.25" between the jaws) and closed jaw dimension (0.030" minimum overlap on centerline). Inspect blades for wear or nicks and replace if necessary.

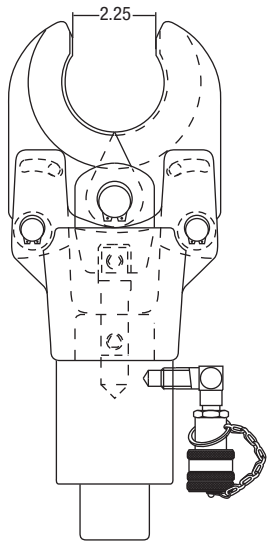

Figure 1

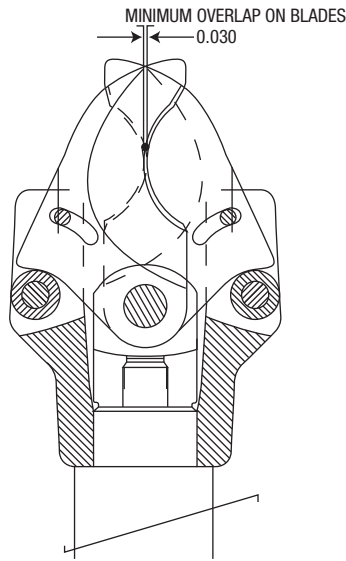

Figure 2

Troubleshooting

If the jaws cannot be adjusted to an opening of 2.25":

1. Check hydraulic fluid level. Add fluid if necessary.
2. Inspect the cutter jaw pin (10). Replace cutter jaw pin if it is bent or broken.

If the cutter jaws do not overlap at least 0.030" on centerline:

1. Remove and inspect roller pins (5). Replace if worn or damaged.
2. Remove and inspect pins (10). Replace if worn or damaged.
3. Replace the cutter jaws (3).

If the cutter jaws do not open properly, see the disassembly, repair, cleaning, and lubricating instructions under Disassembly and Reassembly.

Disassembly and Reassembly

1. Turn the set screw (30) counterclockwise.
2. Unscrew the body (1) of the 751 from the ram (B).
3. Drive the two pins (10) out of the body, and pull the yoke pin (4) from the yoke (1).
4. Check the yoke (2) and the body (1) for galling. Remove small nicks and scratches with a fine cutting file.

Note: Remove as little material as possible. Removing too much will cause the jaws to spread, resulting in incomplete cutting action.

5. Clean the parts by loosening grit and particles of metal with a small brush.

	⚠ WARNING
	<p>Wear eye protection when operating or servicing this tool.</p> <p>Failure to wear eye protection could result in serious eye injury from flying debris or hydraulic oil.</p>

6. Replace any other parts that show signs of wear or damage.
7. Lubricate the contact surfaces of all moving parts with a light coat of moly-filled grease.
8. Insert the shaft (13) into the yoke (2). Turn the shaft clockwise until it is flush with the radius in the yoke.
9. Place a few drops of grade CV Loctite® onto the set screw (9) and tighten the set screw.
10. Insert the yoke pin (4) into the yoke (1).
11. Insert the two pins (10) into the body.
12. Insert the ram into the cutter head unit. Thread the 746 onto the draw stud.
13. Turn the 746 clockwise until the jaw opening measures 2.25". See Figure 1.
14. Apply grade CV Loctite® to the set screw (30) and tighten the set screw.

Illustration

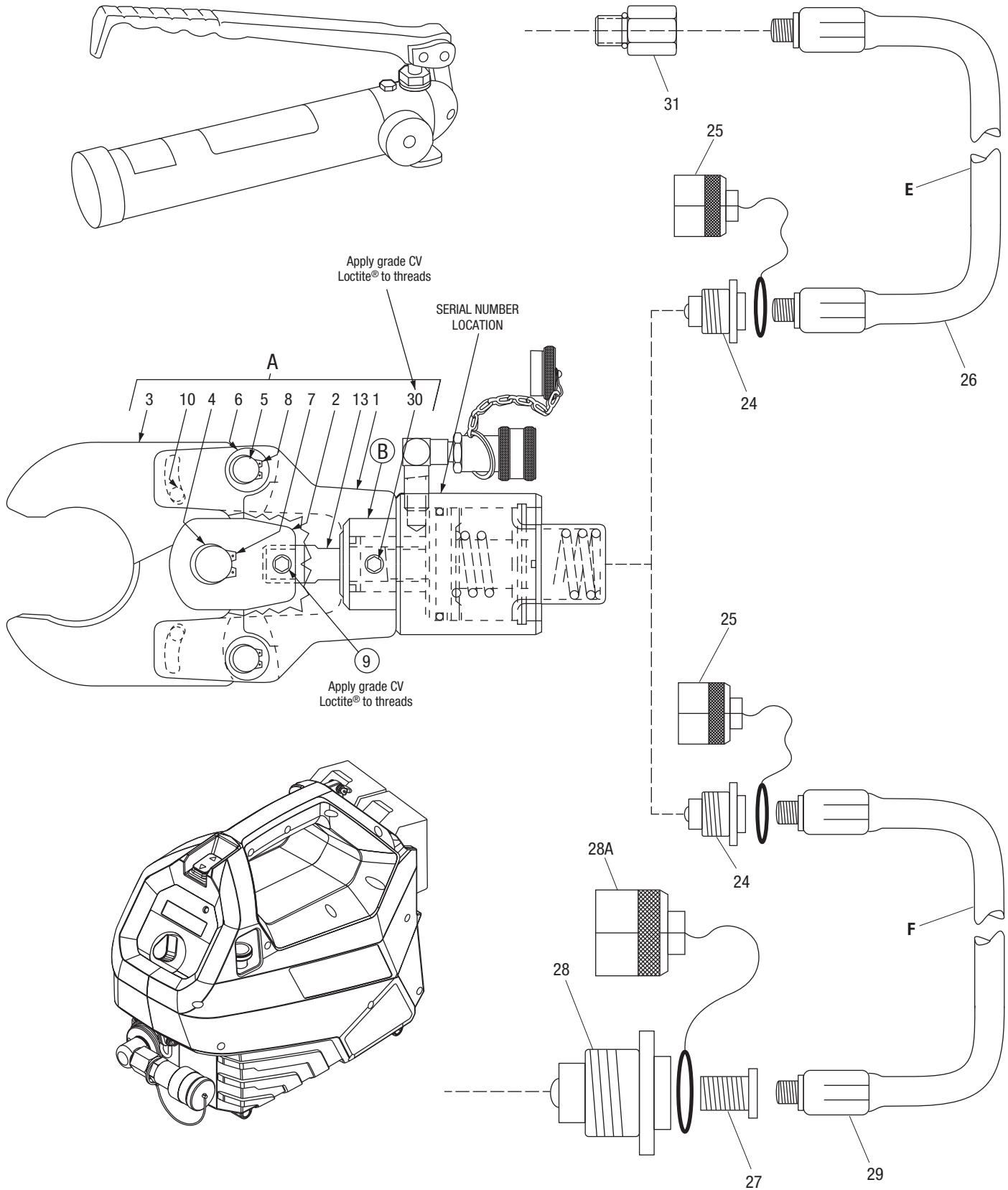

Illustration

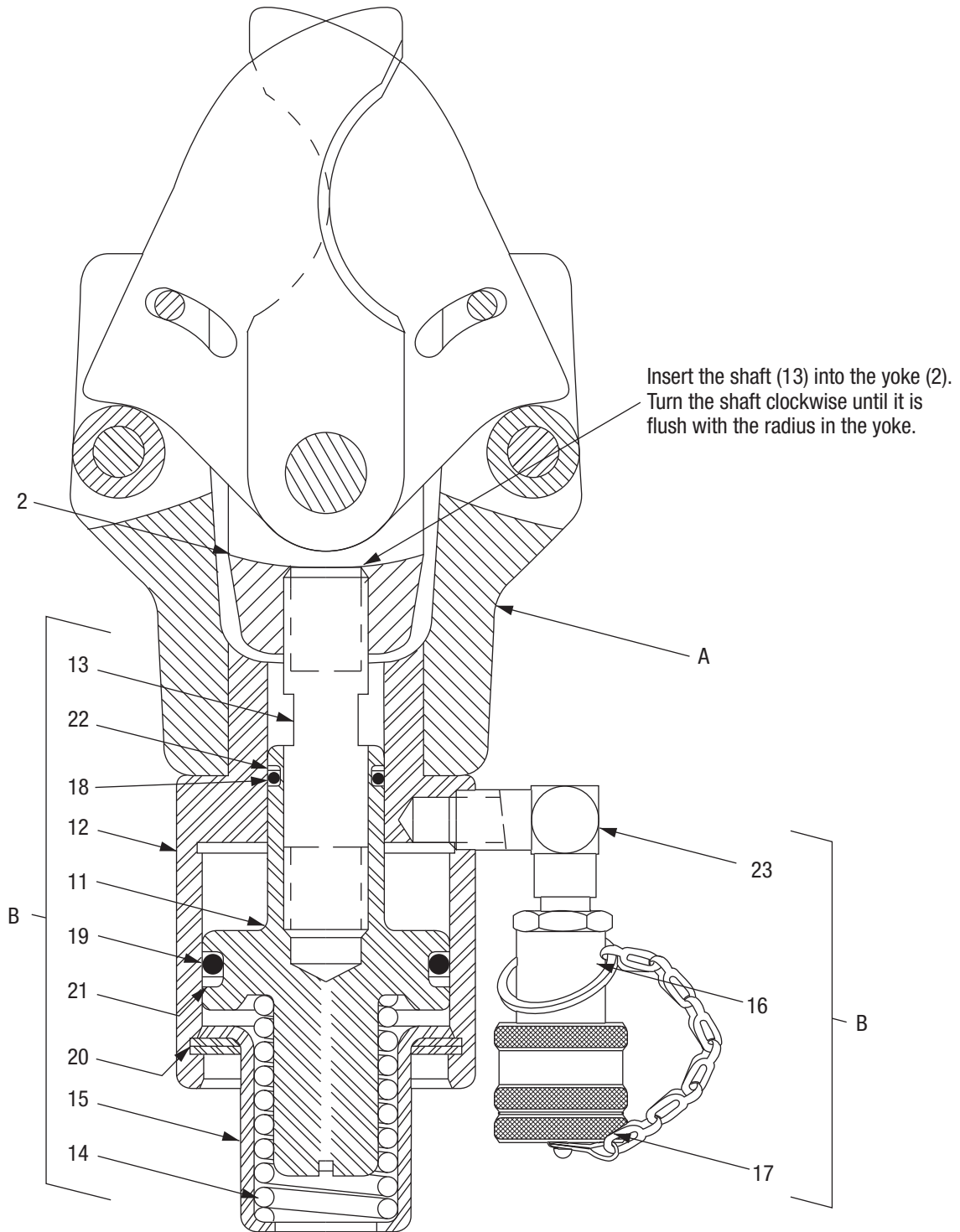

Parts List

Key	Part No.	Description	Qty
A	50222791	Cutter Head 751 (includes items 1-10, 13)	1
1	50328905	Body.....	1
2	50178695	Yoke	1
3	50174592	Cutter Jaw.....	2
4	50174606	Yoke Pin	1
5	50329367	Roller Pin.....	2
6	50174622	Roller	2
7	90502833	Retaining Ring.....	2
8	90513797	Retaining Ring.....	4
9	90522338	Screw, 1/4-20 NC x 3/8 Brass Tip Skt. Set.....	1
10	90536231	Pin, 1/4 x 1-1/2	2
B	50379852	Hydraulic Ram (includes items 11-23)	1
11	50170937	Piston	1
12	50170953	Cylinder.....	1
13	50174533	Shaft.....	1
14	50112511	Compression Spring	1
15	50112538	Retainer.....	1
16	90541677	Quick-Coupler, 1/4 Female Half.....	1
17	90541685	Protective Plug.....	1
18	90503384	O-ring, 7/8 x 1-1/8 x 1/8	1
19	90503899	O-ring, 2 x 2-3/8 x 3/16	1
20	90503902	Retaining Ring.....	2
21	90508327	Backup Ring, 2 x 2-3/8 x 3/16	1
22	90513398	Backup Ring, 7/8 x 1-1/8 x 1/8.....	1
23	90541880	Elbow, Street, 90° x 1/4 NPTF Pipe	1
C	50132849	Hydraulic Hand Pump model 767 (see Parts List IM 727)	1
D	50335162	Hydraulic Power Pump model 975 (see Parts List IM 1021).....	1
E	50383167	Hose Unit (includes items 24-26).....	1
F	50177079	Hose Unit (includes items 24-25, 27-29)	1
24	90541693	Quick-Coupler, 1/4 Male Half.....	1
25	90541707	Protective Cap	1
26	90503864	High Pressure Hose, 1/4 x 3	1
27	90504267	Steel Reducing Bushing, 3/8" x 1/4"	1
28	90508238	Quick-Coupler, 3/8 Male Half with Dust Cap	1
28A	90508467	Protective Cap	1
29	90525159	High Pressure Hose, 1/4 x 10	1
30	90522346	Screw, 5/16"-24 NF x 1/2 Brass Tip Skt. Set.....	1
31	90551605	Connector with O-ring, 7/16-20 x 1/4 Pipe (if necessary).....	1
	52081519	Decal, Warning (not shown)	1
	50174886	Decal, Caution (not shown).....	1
750 H 767	50174509	Cable Cutter with 767 Hand Pump (includes A, B, C, E)	
750 E 975	50177087	Cable Cutter with 975 Electric Power Pump (includes A, B, D, F)	
750	50291491	Cable Cutter with Ram (includes A and B)	
751	50222791	Cutter Head Unit (includes A)	