

INSTRUCTION MANUAL

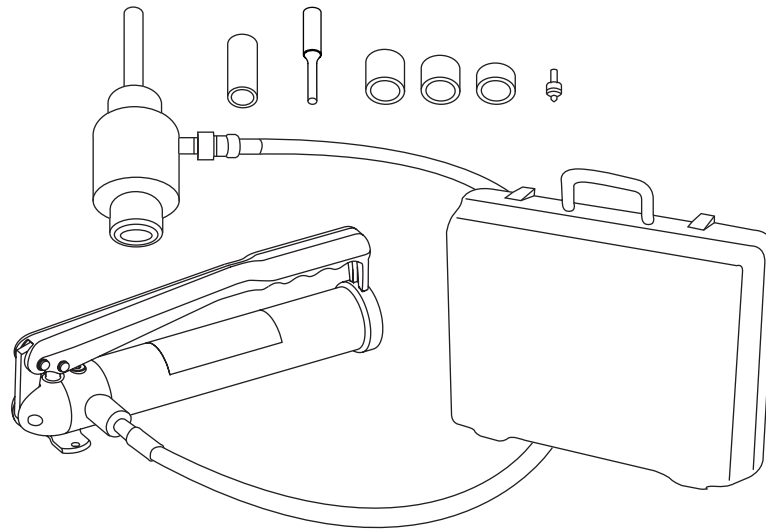

Hydraulic Punch Driver

**38456, 38520, 7306/7306SB,
7310/7310SB, 7506, 7606SB, 7610SB,
7625/7625Pg/7625PgSB,
7646/7646Pg/7646PgSB**



Read and understand all of the instructions and safety information in this manual before operating or servicing this tool.

Register this product at www.greenlee.com

Table of Contents

Description	2
Safety	2
Purpose of this Manual	2
Important Safety Information	3-4
Setup and Operation Instructions	5
Illustrations and Parts Lists	6-9
Maintenance	10
Repair	10

Description

The Greenlee hydraulic punch driver sets combine the 746 Hydraulic Ram with the 767 Hand Pump or the 1725 Foot Pump. These hydraulic driver sets are intended to be used with either standard or Slug-Buster® punches and dies to punch holes through plastic, fiberglass, aluminum, and steel. Greenlee Slug-Splitter® punches, dies, and draw studs are capable of punching through all of these materials and stainless steel.

Round punches are available for punching holes from 12.7 mm through 144 mm (1/2" through 5-5/8") in diameter, including 1/2" through 5" conduit and pipe sizes. Other shapes are available — square, special square, rectangular, "D", double "D", electronic connector, oiltight with notches, and key.

The maximum thickness of material that the punch can penetrate depends on the size and shape of the punch. Refer to the instruction manual supplied with the punch for individual punch capacities.

Safety

Safety is essential in the use and maintenance of Greenlee tools and equipment. This instruction manual and any markings on the tool provide information for avoiding hazards and unsafe practices related to the use of this tool. Observe all of the safety information provided.

Purpose of this Manual

This manual is intended to familiarize all personnel with the safe operation and maintenance procedures for the following Greenlee hydraulic punch driver kits:

- 38456
- 38520
- 7306/7306SB
- 7310/7310SB
- 7506
- 7606SB
- 7610SB
- 7625/7625Pg/7625PgSB
- 7646/7646Pg/7646PgSB

Keep this manual available to all personnel.

Replacement manuals are available upon request at no charge at www.greenlee.com.

All specifications are nominal and may change as design improvements occur. Greenlee Textron Inc. shall not be liable for damages resulting from misapplication or misuse of its products.

Kwik-Stepper, Slug-Buster, and Slug-Splitter are registered trademarks of Greenlee Textron Inc.

KEEP THIS MANUAL

IMPORTANT SAFETY INFORMATION



SAFETY ALERT SYMBOL

This symbol is used to call your attention to hazards or unsafe practices which could result in an injury or property damage. The signal word, defined below, indicates the severity of the hazard. The message after the signal word provides information for preventing or avoiding the hazard.

⚠ DANGER

Immediate hazards which, if not avoided, **WILL** result in severe injury or death.

⚠ WARNING

Hazards which, if not avoided, **COULD** result in severe injury or death.

⚠ CAUTION

Hazards or unsafe practices which, if not avoided, **MAY** result in injury or property damage.



⚠ WARNING

Read and understand all of the instructions and safety information in this manual before operating or servicing this tool.

Failure to observe this warning could result in severe injury or death.

⚠ WARNING



Electric shock hazard:

Do not use this tool near live circuits. This includes, but is not limited to, the following:

- near circuit breaker panels or fuse boxes with energized circuits
- near junction boxes with energized circuits

Failure to observe this warning could result in severe injury or death.

⚠ WARNING



Skin injection hazard:

- Hand-tighten all couplers completely before operating the pump. Do not use tools to tighten the couplers.
- Do not use hands to check for leaks.
- Do not hold hose or couplers while the hydraulic system is pressurized.
- Release the hydraulic pressure before disconnecting the hoses or couplers, and before servicing the pump or accessory.

Oil under pressure easily punctures skin causing serious injury, gangrene or death. If you are injured by escaping oil, seek medical attention immediately.

⚠ WARNING



Wear eye protection when operating or servicing this tool.

Failure to wear eye protection could result in serious eye injury from flying debris or hydraulic oil.

IMPORTANT SAFETY INFORMATION

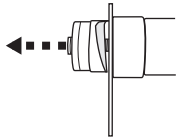
	⚠ WARNING
	<p>A component failure could throw broken parts.</p> <ul style="list-style-type: none"> Do not allow anyone to stand in front of the punch or behind the hydraulic ram. Close access doors or covers on any equipment that is in line with the punch or ram. <p>Failure to observe this warning could result in severe injury or death.</p>

⚠ WARNING
<p>Replace worn, damaged or missing components with Greenlee replacement parts. Worn or damaged components can fail, resulting in injury or property damage.</p> <ul style="list-style-type: none"> Inspect the pump, hoses, couplers, and fittings for wear or damage. Inspect all punch components (punch, die, draw stud, etc.) for wear or damage. <p>Failure to observe these warnings could result in severe injury or death.</p>

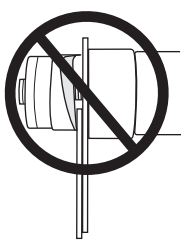
	⚠ WARNING
	<p>Do not attempt to punch a hole through two or more layers of material. This will bend or break the draw stud, and could throw parts with great force.</p> <p>Failure to observe this warning could result in severe injury or death.</p>

⚠ WARNING
<p>Do not exceed the rated capacity of this tool. Exceeding the rated capacity could cause a component failure, which could throw broken parts with great force.</p> <p>Failure to observe this warning could result in severe injury or death.</p>

⚠ WARNING
<p>Set up the tool properly. An improper setup could cause a component to fail and strike nearby personnel with great force.</p> <ul style="list-style-type: none"> Thread the punch completely onto the draw stud. All of the punch threads must be engaged by the draw stud threads. Incomplete assembly could cause a component failure. Use only Greenlee punches, dies, and draw studs. Other manufacturers' components might not withstand the forces generated by this punch driver. <p>Failure to observe these warnings could result in severe injury or death.</p>

⚠ CAUTION
<p>The punch driver will fall free when the punch is complete.</p> <ul style="list-style-type: none"> Support the weight of the tool when punching. Do not allow anyone to stand beneath an overhead punch. <p>Failure to observe this warning may result in injury or property damage.</p>

⚠ CAUTION
<p>Use this tool for the manufacturer's intended purpose only. Any other use may result in injury or property damage.</p>

⚠ WARNING
<p>This punch system was designed for a maximum operating pressure of 450 bar (6500 psi).</p> <ul style="list-style-type: none"> Use this punch system with the Greenlee 767 Hand Pump or 1725 Foot Pump only. Connect the pump to the ram with Greenlee hoses and couplers only. <p>Use of any other hoses or couplers could result in injury from a component failure.</p>

Setup and Operation Instructions

1. Remove the dust caps from the couplers; attach the hose to the ram and to the pump. Thread the dust caps together.

Note: Hand-tighten the couplers completely until all threads are engaged. Do not use tools.

2. Select the punch, die, and draw stud that will make the appropriate size hole.
3. Determine and mark the exact location for the hole. Using a drill bit that is slightly larger than the draw stud, drill a hole. This is the *pilot hole*.

4. Thread the 3/4" piston shaft (B) completely into the ram (A). Refer to the illustration.

Note: For a punch and die with a 3/8" center hole, thread the 3/8" adapter draw stud (F) into the end of the piston shaft. For a punch and die with a 1-1/8" center hole, thread the screw sleeve (E) onto the piston shaft.

5. Install spacers as necessary. Refer to the illustrations on this page.
6. Slide the die over the draw stud with the open end of the die facing away from the ram.
7. Insert the draw stud through the pilot hole.

8. Thread the punch onto the draw stud with the cutting surfaces of the punch facing the material. Tighten the punch by hand until the spacers, die, material, and punch are snug.

Note: All of the punch threads must be engaged by the draw stud threads. If any of the punch threads are not engaged, dis-assemble the setup, remove one of the spacers, and reassemble the setup.

⚠ CAUTION

Do not operate the pump after ram motion stops. Continuing to operate the pump lever after the ram stops will damage the ram.

Note: If the ram stops before the hole is complete, stop pumping. Check that the setup is correct and that you have not exceeded the tool's capacity. Refer to the setup instructions. If necessary, disassemble the setup and add a spacer.

9. Activate the pump. For specific instructions, refer to the operating manual supplied with the pump.

Note: Support the weight of the ram when operating the pump. This will prevent the ram from falling when the punch is complete.

10. Release the pressure at the pump.

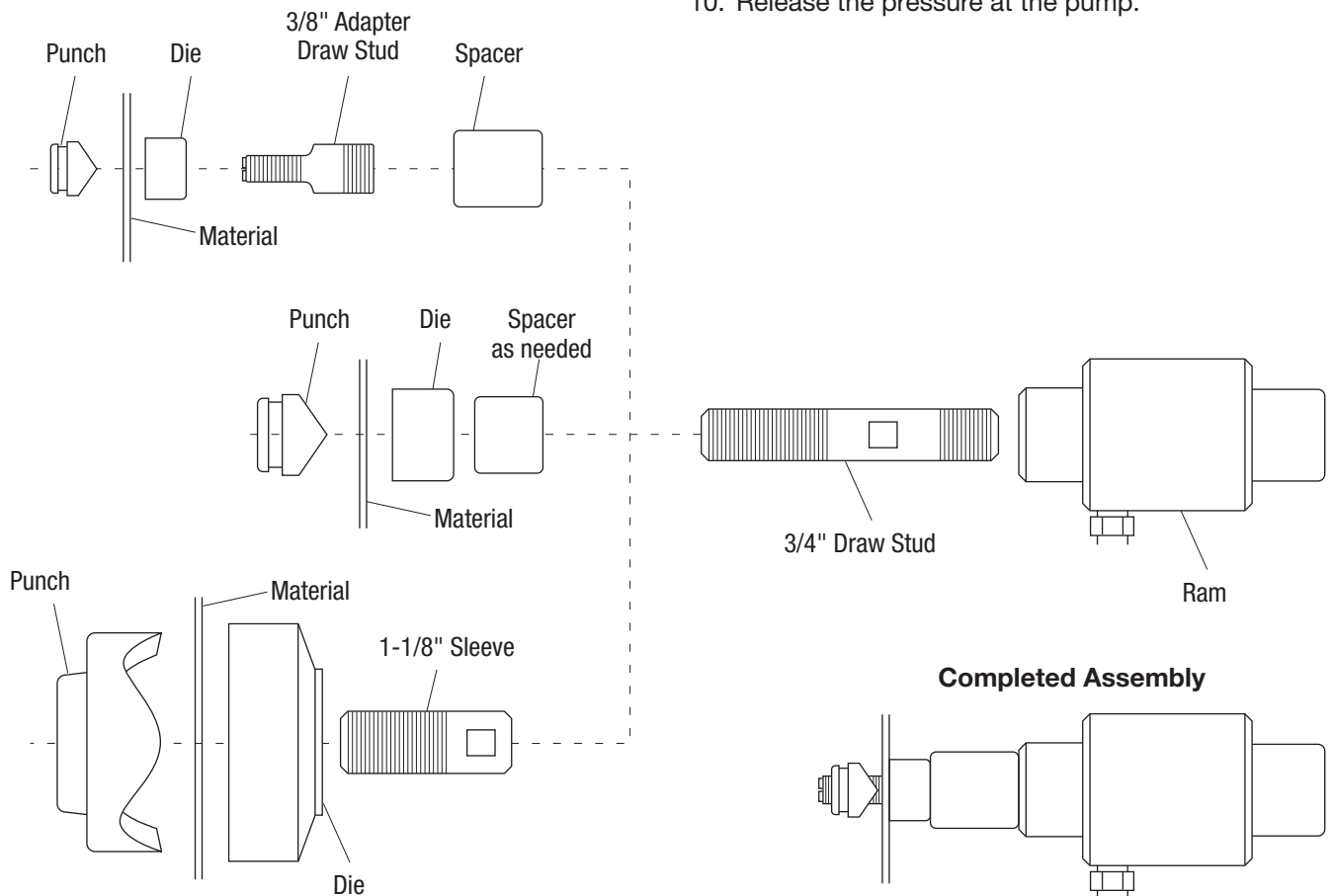

Illustration—Punch Driver

7646 Hydraulic Punch Driver with 767 Hand Pump

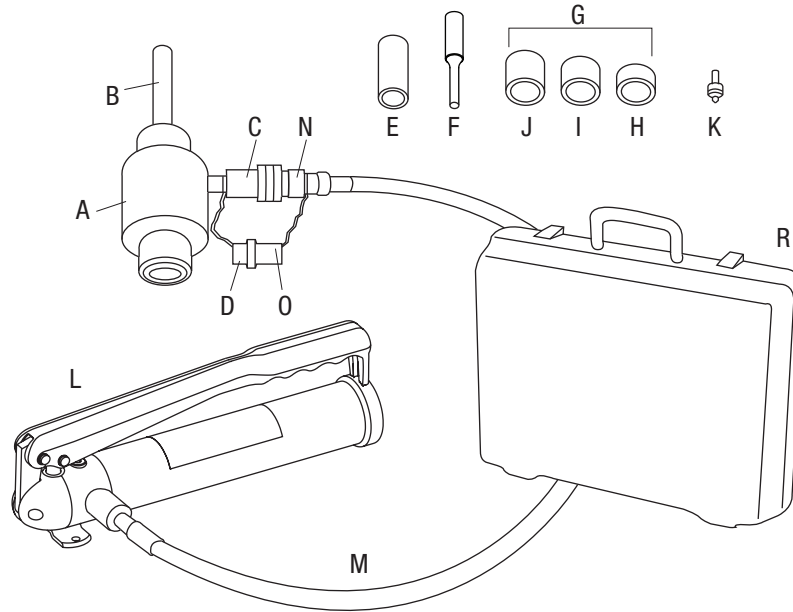

7625 Hydraulic Punch Driver with 1725 Foot Pump

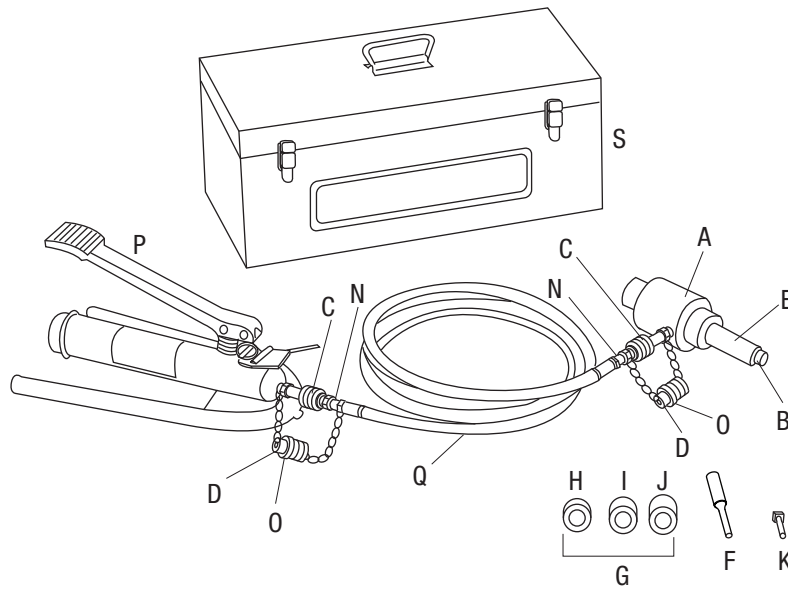

For punching mild steel, 3/8" drive:

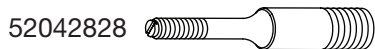

For punching stainless steel:

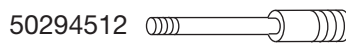

(for use with Slug-Splitter punches and dies)

Parts List—Punch Driver

Key	Cat. No.	UPC No. 78-3310-	Description	7646	7306SB	7306	7310SB	38520	7310	38456	7625	7606SB	7610SB	7304	7506
A	746	17091	Ram (includes keys B, C, D)	1	1	1	1	1	1	1	1	1	1		
	746SS	30387	Ram (includes keys C, D and 29452)												1
	29451	29451	7/16" Stainless Steel Draw Stud												1
	29452	29452	3/4" Stainless Steel Draw Stud												1
B	2113B	10109	3/4" Piston Shaft	1	1	1	1	1	1	1	1	1	1		
C	54167	54167	1/4" Coupler Unit	1	1	1	1	1	1	1	2	2	2		1
D	54168	54168	Dust Plug	1	1	1	1	1	1	1	2	2	2		1
E	1557AA	03170	Screw Sleeve	1	1	1	1	1	1	1	1	1	1		
F	20963	20963	3/8" Adapter Draw Stud (3/4-16 x 3/8-24)	1	1	1	1	1	1	1	1	1	1		
G	15908	15908	Spacer Group (includes keys H, I, J)	1	1	1	1	1	1	1	1	1	1		1
H	1924AA	03248	Short Spacer	1	1	1	1	1	1	1	1	1	1		1
I	1925AA	03249	Medium Spacer	1	1	1	1	1	1	1	1	1	1		1
J	1926AA	06904	Long Spacer	1	1	1	1	1	1	1	1	1	1		1
K	34410	34410	Kwik-Stepper® Pilot Bit	1	1	1	1	1	1	1	1	1	1		1
L	767	13284	Hydraulic Hand Pump	1	1	1	1	1	1	1					1
M	38316	38316	1/4" x 3' High-Pressure Hose Unit (includes keys N, O)	1	1	1	1	1	1	1					1
N	54169	54169	1/4" Coupler Unit	1	1	1	1	1	1	1	2	2	2		1
O	54170	54170	Dust Cap	1	1	1	1	1	1	1	2	2	2		1
	06302	06302	1/4" x 3' High-Pressure Hose with Swivel (without couplers)	1	1	1	1	1	1	1					1
P	1725	31353	Hydraulic Foot Pump (includes keys C, D)								1	1	1		
Q	37729	37729	1/4" x 10' High Pressure Hose Unit (includes two each of keys N, O)								1	1	1		
	52515	52515	1/4" x 10' High Pressure Hose Replacement (without couplers)												
R	30206	30206	Plastic Carrying Case, 1/2"-2" Conduit	1	1	1									
R	05387	05387	Plastic Carrying Case, 1/2"-4" Conduit				1	1	1	1					
S	23955	23955	Metal Carrying Case								1	1	1		
	30236	30236	Plastic Carrying Case, 2-1/2"-4" Conduit											1	
	31068	31068	Metal Carrying Case												1

Parts List—Punches

- Standard and Slug-Buster punches, dies, and draw studs listed in the following table are capable of punching a maximum of 10 (0.1344", 3 mm) gauge mild steel.
- Slug-Splitter punches, dies, and draw studs listed in the following table are capable of punching a maximum of 10 (0.1344", 3 mm) gauge stainless steel.

Cat. No.	UPC No. 78-3310-	Description	7646	7306SB	7306	7310SB	38456	7310	38520	7625	7606SB	7610SB	7304	7506
721-1/2	31756	1/2" Slug-Buster Punch		1	1	1	1	1	1		1	1		
14722	14722	1/2" Die		1	1	1	1	1	1		1	1		
721-3/4	31757	3/4" Slug-Buster Punch		1		1			1		1	1		
123AV	04008	3/4" Standard Punch			1		1	1						
124AV	06972	3/4" Die		1	1	1	1	1	1		1	1		
721-1	31758	1" Slug-Buster Punch		1		1			1		1	1		
125AV	04010	1" Standard Punch			1		1	1						
126AV	04011	1" Die		1	1	1	1	1	1		1	1		
721-1-1/4	31759	1-1/4" Slug-Buster Punch		1		1			1		1	1		
127AV	06974	1-1/4" Standard Punch			1		1	1						
128AV	04013	1-1/4" Die		1	1	1	1	1	1		1	1		
721-1-1/2	31760	1-1/2" Slug-Buster Punch		1		1			1		1	1		
439AV	06978	1-1/2" Standard Punch			1		1	1						
440AV	04061	1-1/2" Die		1	1	1	1	1	1		1	1		
721-2	31761	2" Slug-Buster Punch		1		1			1		1	1		
441AV	04062	2" Standard Punch			1		1	1						
442AV	04063	2" Die		1	1	1	1	1	1		1	1		
1429AV	04175	2-1/2" Punch				1	1	1	1			1	1	
1430AV	04177	2-1/2" Die				1	1	1	1			1	1	
1431AV	04180	3" Punch				1	1	1	1			1	1	
1432AV	04183	3" Die				1	1	1	1			1	1	
2982AV	04653	3-1/2" Punch				1		1				1	1	
2981AV	04652	3-1/2" Die				1		1				1	1	
2984AV	04655	4" Punch				1	1	1	1			1	1	
2983AV	04654	4" Die				1	1	1	1			1	1	
28154	28154	1/2" Slug-Splitter Punch												1
28155	28155	1/2" Slug-Splitter Die												1
28156	28156	3/4" Slug-Splitter Punch												1
28157	28157	3/4" Slug-Splitter Die												1
28158	28158	1" Slug-Splitter Punch												1
28159	28159	1" Slug-Splitter Die												1
28160	28160	1-1/4" Slug-Splitter Punch												1
28161	28161	1-1/4" Slug-Splitter Die												1
28162	28162	1-1/2" Slug-Splitter Punch												1
28163	28163	1-1/2" Slug-Splitter Die												1
28165	28165	2" Slug-Splitter Punch												1
28166	28166	2" Slug-Splitter Die												1

Illustration and Parts List—Ram

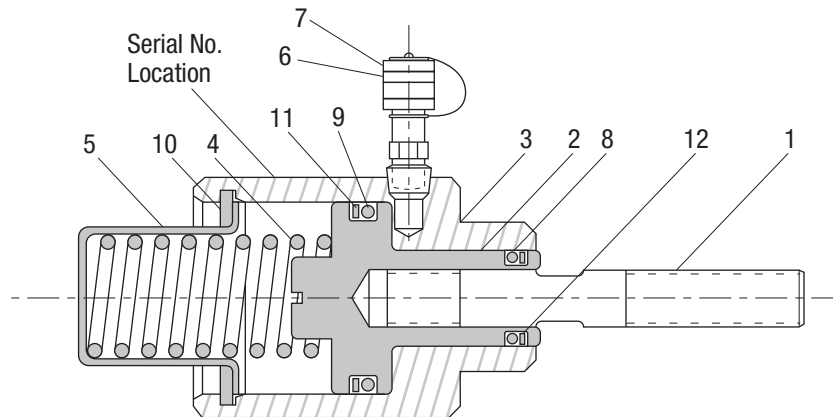

Key	Part No.	Description	Qty
1*	52045040	Shaft (746 M-3)	1
	50294520	Shaft (746 SS)	1
2**	50170937	Piston	1
3	50170953	Cylinder	1
4	50112511	Spring, Compression	1
5	50112538	Retainer	1
6	90541677	Coupler, 1/4" Quick Disconnect	1
7	90541685	Plug, Protective	1
8	90503384	O-ring, 7/8" x 1-1/8" x 1/8"	1
9	90503899	O-ring, 2" x 2-3/8" x 3/16"	1
10	90503902	Ring, Retainer	2
11	90508327	Ring, 2" x 2-3/8" x 3/16" Spiral Backup	1
12	90513398	Ring, 7/8" x 1-1/8" x 1/8" Spiral Backup	1
	50145525	Packing Repair Kit (includes items 8, 9, 11, and 12)	1
	50121219	Decal, Safety (not shown)	1
*	52045041	Supplied with the 746 and used with standard punches and Slug-Buster punches	
**	50294520	Supplied with the 746 SS and used with Slug-Splitter punches and dies	

Maintenance

The pump and ram require little maintenance. Use the tool with care to keep dirt and grit out of the hydraulic system. All internal working parts are lubricated by the hydraulic oil, so that no other lubrication is necessary.

Repair

All repair work should be performed at an authorized Greenlee service center. Use only Greenlee replacement parts. Using any parts other than Greenlee replacement parts may do irreparable damage and will void the warranty.