

# OPERATION, SERVICE AND PARTS INSTRUCTION MANUAL

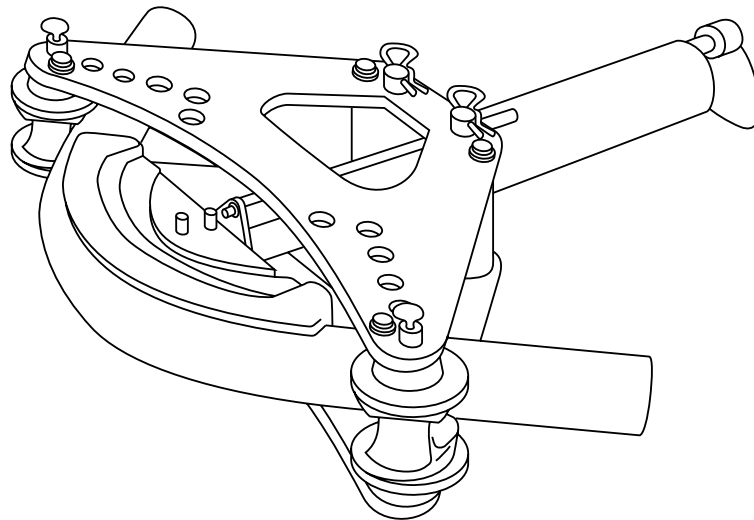

## 880 HYDRAULIC BENDER



**Read and understand** this material before operating or servicing this tool. Failure to understand how to safely operate this tool could result in an accident causing serious injury or death.

**Table of Contents**

Safe Operating Practices ..... 2-3  
 Description and Purpose ..... 3  
 Operating Instructions  
     Setup ..... 4  
     Bending Conduit ..... 5  
 Bending Instructions  
     Glossary of Bending Terms (with Illustrations) ..... 6  
     Laying Out One-Shot 90° Bends ..... 7  
     Laying Out an Offset Bend ..... 8  
         Calculating the Center-to-Center Distance ..... 8  
         Calculating Shrink ..... 9  
     Laying Out a Segment Bend ..... 10-12  
     Other Bending Information ..... 12-13  
 Maintenance  
     Exploded View and Parts List ..... 14  
     Frame Unit—Parts Lists ..... 15  
     Ram—Parts List ..... 16



**SAFETY  
ALERT  
SYMBOL**

The symbol above is used to call your attention to instructions concerning your personal safety. Watch for this symbol. It points out important safety precautions. It means **“ATTENTION! Become alert! Your personal safety is involved!”** Read the message that follows and be alert to the possibility of personal injury or death.

**⚠ DANGER**

Immediate hazards which, if not avoided, **WILL** result in severe personal injury or death.

**⚠ WARNING**

Hazards or unsafe practices which, if not avoided, **COULD** result in severe personal injury or death.

**⚠ CAUTION**

Hazards or unsafe practices which, if not avoided, **COULD** result in minor personal injury or property damage.

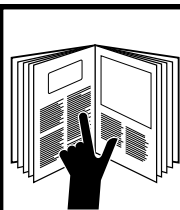

**⚠ WARNING**

A person who has not read and does not understand all operating instructions is not qualified to operate this tool.

Failure to read and understand safety instructions may result in injury or death.

## **IMPORTANT SAFETY INSTRUCTIONS**

	<p style="text-align: center;"><b>⚠ WARNING</b></p> <p>Pinch points. Keep hands away from bending shoe, pipe supports, and conduit when bender is in use.</p>
---	---

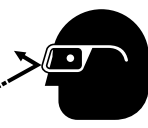
	<p style="text-align: center;"><b>⚠ WARNING</b></p> <p>Wear eye protection when operating the bender.</p> <p>Failure to wear eye protection can result in serious eye injury from flying debris and hydraulic oil.</p>
---	--

<p style="font-size: 1.2em;"><b>⚠ WARNING</b></p>
<ul style="list-style-type: none"> <li>• Do not stand in direct line with the hydraulic ram. A component failure could propel parts with sufficient force to cause severe injury or death.</li> <li>• Do not operate while wearing loose clothing. Loose clothing could get caught in moving parts.</li> </ul> <p>Failure to observe these warnings can result in severe injury or death.</p>

<p style="font-size: 1.2em;"><b>⚠ CAUTION</b></p>
<ul style="list-style-type: none"> <li>• Conduit moves rapidly as it is bent. The path of the conduit must be clear of obstructions. Be sure clearance is adequate before starting the bend.</li> <li>• Inspect the bender, pump, and hose before each use. Replace damaged, worn or missing parts with Greenlee replacement parts. A damaged or improperly assembled component could break and strike nearby personnel.</li> <li>• Some of the bender parts and accessories are heavy and may require more than one person to lift and assemble.</li> </ul> <p>Failure to observe these precautions can result in injury or property damage.</p>

<p style="font-size: 1.2em;"><b>IMPORTANT</b></p>
<p>Make sure all hose fittings are properly seated before starting the bend. Incomplete connections may not allow the ram to retract after the bend is complete.</p>

### **Description**

The Greenlee 880 Hydraulic Bender is intended to bend 1/2" - 2" GRC (galvanized rigid conduit) and schedule 40 pipe when used with standard aluminum bending shoes. The 880 bends up to 90° in one shot.

- Standard aluminum shoes bend 1" - 2" GRC and schedule 40 pipe.
- Optional aluminum shoes bend 1/2" and 3/4" GRC and schedule 40 pipe.
- Optional PVC-type shoes are available for bending 1/2" through 2" PVC-coated rigid conduit.
- Optional ductile iron bending shoes are available for bending 1" - 2" schedule 80 pipe.

The bender is to be coupled to any Greenlee hydraulic pump capable of developing 10,000 psi. Suggested pumps are models 755, 975, 976-22FS, 976-22PS, 980, 980-22FS, 980-22PS, and 960 SAPS.

### **Purpose**

This instruction manual is intended to familiarize operators and maintenance personnel with the safe operation and maintenance procedures for the 880 Conduit Bender.

## **SAVE THESE INSTRUCTIONS**

Additional copies of this manual are available upon request at no charge.

## Operating Instructions

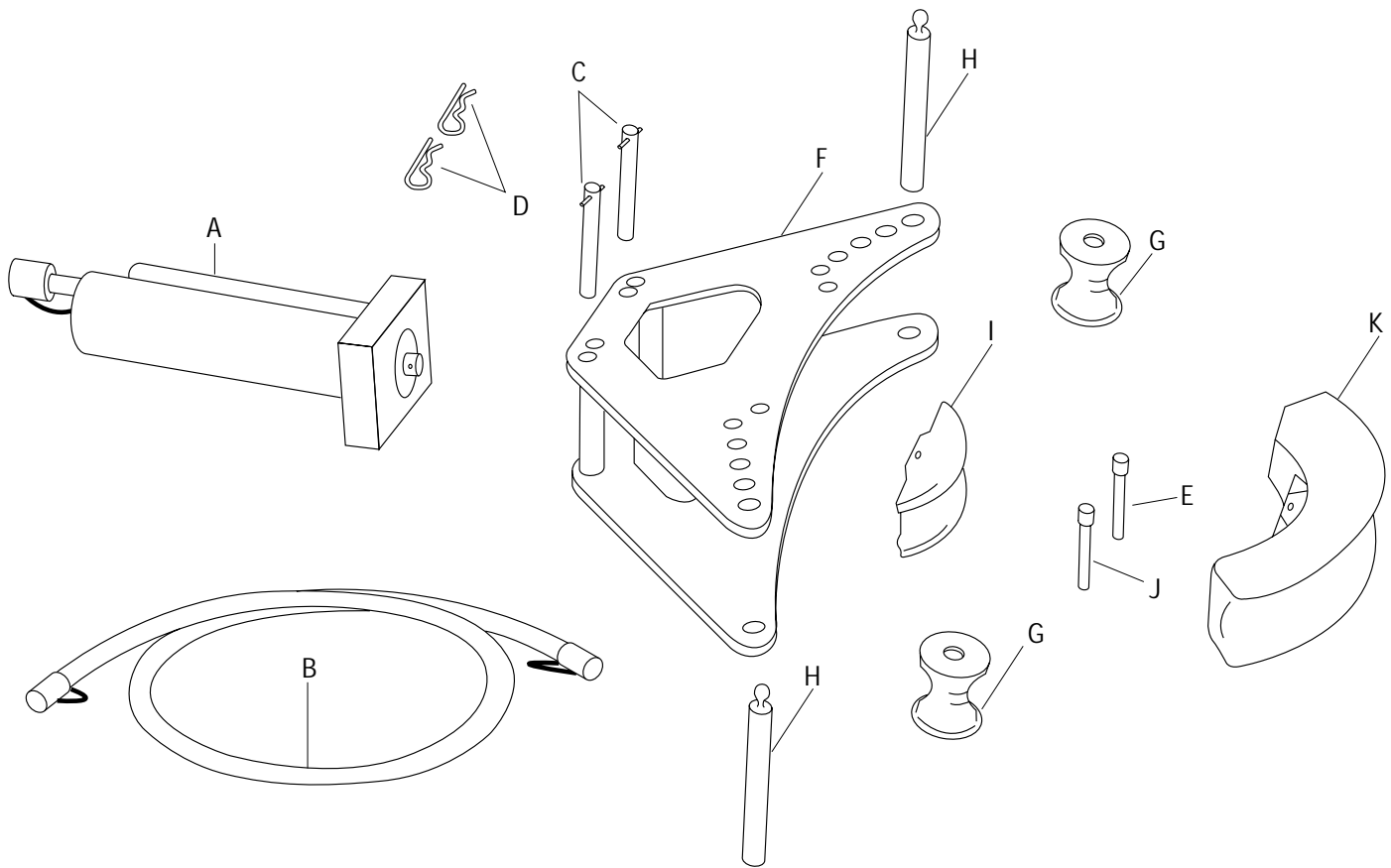

### Setup

1. Place the ram (A) between the two halves of the frame unit (F).
2. Insert the cylinder head pins (C) through the frame unit (F) and ram (A). Secure the cylinder head pins in place with the spring clips (D).
3. Select the bending shoe (K) that corresponds to the size of conduit to be bent.
4. Attach the shoe to the shoe support (K) with the shoe pin (J). Attach the shoe support to the ram (A) with the ram pin (E).
5. Place the pipe supports (G) into the frame, locating them in the hole positions that correspond to the size of conduit or pipe to be bent. Insert the pipe support pins (H) through the upper frame, through the pipe support, and through the lower frame. Turn the thumb screws clockwise to secure the pipe supports.
6. Position the pipe support so that the side of the pipe support facing the conduit corresponds to the size of conduit to be bent.
7. Connect the high-pressure hydraulic hose (B) to the ram (A) and to the pump (not shown).

*Note: Clean the quick-change couplers before making the connections. Hand-tighten the coupler completely. Do not use tools.*

### IMPORTANT

Follow the instructions and safety information supplied with your hydraulic pump.

**Bending Conduit**

1. Loosen the ram travel scale nut; set the ram travel scale, which is read at the edge of the block, to zero. Tighten the nut.
  2. Mark the conduit. See the instructions in this manual for marking the conduit for the necessary bend.
  3. Insert the conduit into the bender. Align the bending mark on the conduit with the center of the bending shoe.
  4. Consult the Ram Travel Table to find the amount of ram travel necessary to accomplish the bend.
  5. Use the hydraulic pump to advance the ram by the amount of ram travel found in step 4.
  6. Release the hydraulic pressure at the pump and move the conduit to the next bending position.
- Note: If making an offset bend, rotate the conduit 180° before making the second bend. If making a three-bend saddle, rotate the conduit 180° before making the second and third bends. If making a four-bend saddle, rotate the conduit 180° before making the second and fourth bends.*
7. Repeat steps 5 and 6 until the last bend is made.
  8. Remove the conduit from the bend.

**Ram Travel Table for Common Bends**

		Angle of Bend					
		10°	15°	30°	45°	60°	90°
Conduit Size	1/2	1-5/8	1-13/16	2-7/16	2-15/16	3-1/2	4-3/8
	3/4	1-5/8	1-13/16	2-3/8	2-7/8	3-5/16	4-1/8
	1	1-11/16	1-15/16	2-11/16	3-5/16	3-13/16	4-7/8
	1-1/4	1-3/4	2-1/16	2-15/16	3-3/4	4-7/16	5-5/8
	1-1/2	1-7/8	2-1/4	3-1/4	4-3/16	5	6-1/2
	2	2	2-7/16	3-9/16	4-7/16	5-5/8	7-1/4

Figures are approximate

*Note: To use this table, find the size of the conduit to be bent in the leftmost column and find the desired angle of bend in the top row. The intersection of the appropriate column and row shows the approximate amount of ram travel necessary to accomplish the desired angle of bend.*

**RAM TRAVEL SCALE**

READ SCALE AT EDGE OF BLOCK

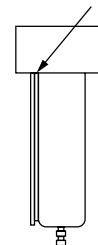

**Centerline Bending Radii for the 880 Bender**

Rigid Shoe Size (inches)	1/2	3/4	1	1-1/4	1-1/2	2
Bending Radius (inches)	4	4-1/2	5-3/4	7-1/4	8-1/4	9-1/2
Bending Radius (cm)	10.16	11.43	14.60	18.41	20.95	24.13

**Bending Instructions**

**Glossary of Bending Terms with Illustrations**

- amount of offset** — the distance that the conduit or pipe must be re-routed to avoid an obstruction; see *offset bend* in this glossary and *Offset Bending Instructions* in this manual.

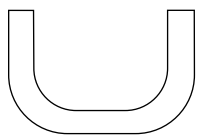

- back-to-back bend** — any U-shaped bend formed by two parallel 90-degree bends with a straight section of conduit or pipe between the bends
- center-to-center distance** — the distance between the successive bends that make up an offset or a three-bend saddle
- degrees per shot** — a segment-bending term which refers to the amount of bend accomplished each time the conduit is bent; to achieve a smooth bend, each shot must accomplish the same number of degrees of bend
- depth of offset** — same as *amount of offset*
- developed length** — the actual length of pipe that will be bent; see distance “C” in the following illustration

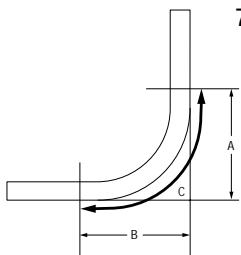

- gain** — because conduit and pipe are bent with a radius and not at right angles, the length of conduit or pipe needed for a bend is less than the straight-line measured length; gain is the difference between the right angle distance (A + B) and the shorter curved distance (C)
- height of offset** — same as *amount of offset*
- kick** — single bend of less than 90°

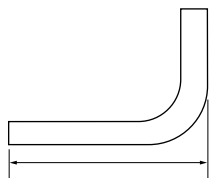

- leg length** — the distance from the end of a horizontal section of conduit or pipe to the bend; measured from the end to the outside edge of the conduit or pipe.

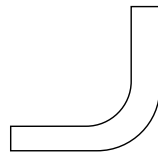

- 90° bend** — any bend that changes the direction of the conduit or pipe by 90° degrees
- number of bending shots** — a segment bending term which refers to the total number of small bends that are required to make up a more gradual segment bend
- O.D.** — the size of any piece of conduit or pipe as measured by its outside diameter
- offset bend** — two bends with the same degree of bend; used to avoid an obstruction blocking the run of the conduit or pipe
- ram travel** — the distance that the ram of the hydraulic bender moves to accomplish a particular bend; inches of ram travel are proportionate to degrees of bend

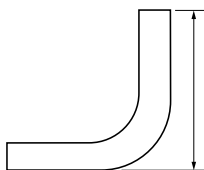

- rise** — the distance from the end of a vertical section of conduit or pipe to the bend; measured to the outside edge of the conduit or pipe
- segment bend** — any bend formed by a series of bends of a few degrees each, rather than a single bend; allows a more gradual bend
- shot** — a single bend; a shot may accomplish a complete bend or, when making a segment bend, several shots may be required to make a more gradual bend

- shrink** — the amount of conduit “lost” when laying out an offset bend working toward an obstruction; see the explanation under *Offset Bending* in this manual
- springback** — the amount, measured in degrees, that a conduit or pipe tends to straighten after being bent
- stub** — same as *rise*
- stub-up** — same as *rise*

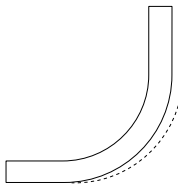

**Laying Out One-Shot 90° Bends**

1. Measure the length of the required stub. See Figure 1.
2. Find the minimum stub length for that diameter of conduit on the Deduct and Minimum Stub Length Table. The stub you require must be equal to or longer than the minimum stub length.
3. Measure and mark the stub length on the conduit. This is mark 1. Subtract the deduct from the stub and mark the conduit. This is mark 2, or the bending mark. See Figure 2.
4. Insert the conduit into the bender so that mark 2, the bending mark, lies at the center of the shoe.
5. Bend the conduit. To achieve the desired angle, refer to the Ram Travel Table for Common Bends in this manual. See Figure 3.

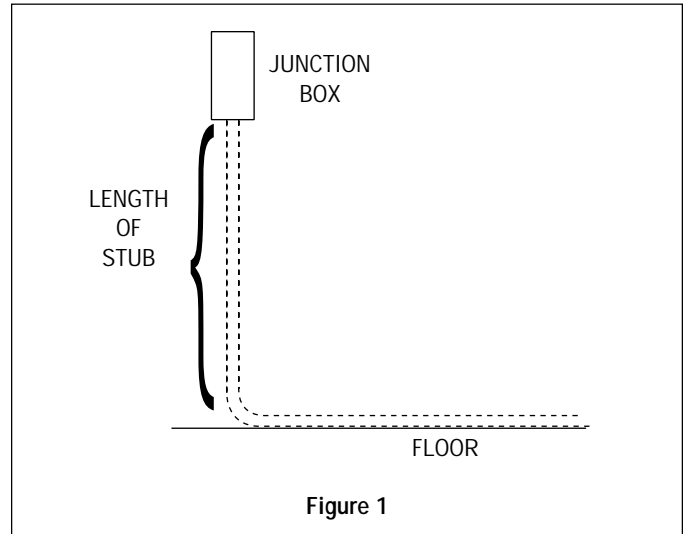

Figure 1

**Deduct and Minimum Stub Length Table**

Conduit Size	1/2	3/4	1	1-1/4	1-1/2	2
Deduct	1-5/16	1-1/2	1-7/8	2-3/8	2-3/4	3-1/4
Minimum Stub Length	9-1/4	9-1/4	11-3/8	13-5/16	15-1/4	17-1/4

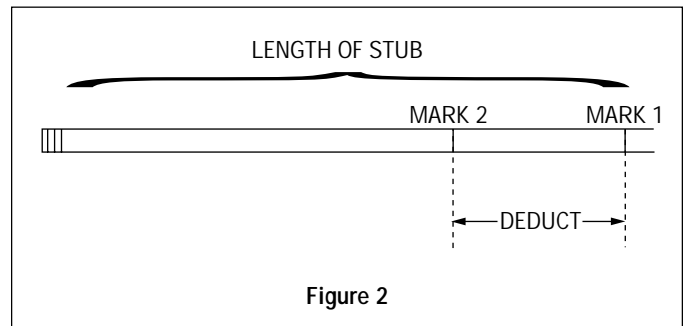

Figure 2

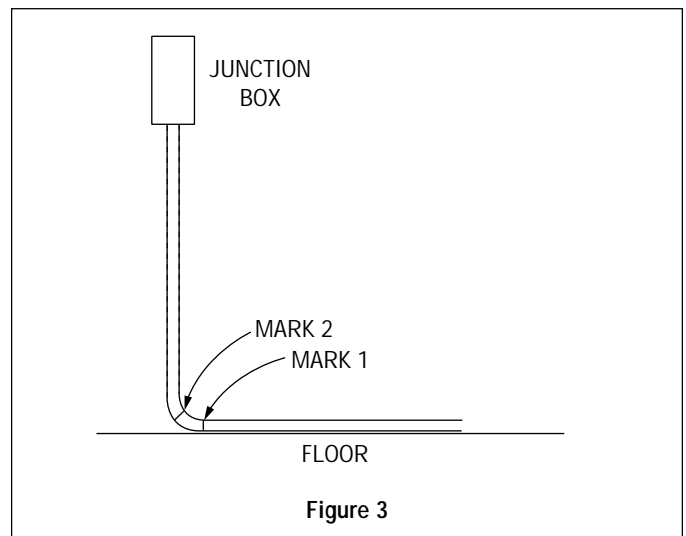
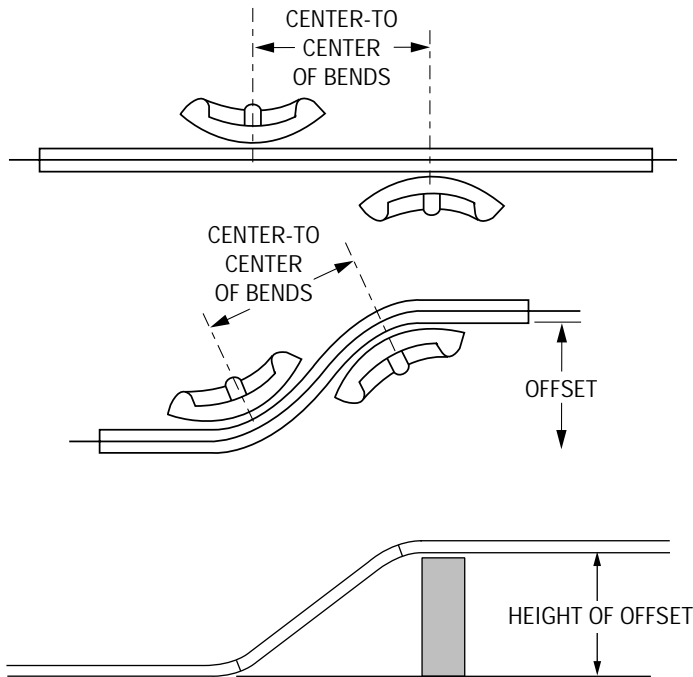

Figure 3

## Laying Out Offset Bends

An offset bend is used to route the conduit around an obstruction. To make an offset, two bends are required. The operator must measure the height of the offset and select the angle of the offset. The distance between the two bends is the center-to-center distance.



1. Measure the obstruction.
  2. Determine the angle of the offset bends.
  3. Calculate the center-to-center distance. See the Greenlee Offset Multiplier and Shrink Table.
- Note: If working toward an obstruction, calculate the amount of shrink. See Calculating "Shrink" in this manual.*
4. Mark the conduit.
  5. See bending instructions under "Bending Conduit" in this manual.

## Calculating the Center-to-Center Distance

To calculate the center-to-center distance of commonly used offset bends, multiply the amount of offset by the appropriate offset multiplier:

### Offset Multipliers

15°	3.86
22-1/2°	2.6
30°	2
45°	1.4
60°	1.2

*To use this table: Measure the obstruction and determine the angle of the offset. Find the angle of the offset in the left column; multiply the height of the obstruction by the corresponding multiplier in the right column to find the center-to-center distance.*

*Example: 5 inches of offset  
15-degree bend*

*Multiplier for 15°: 3.86*

*Multiply the amount of offset by the multiplier to find the center-to-center distance:  $5 \times 3.86 = 19.3$*

*Round off to the nearest common fraction: 19-5/16*

The following Offset Table shows the center-to-center distance for selected amounts of offset for commonly used bends.

**Offset Table**

OFFSET →		2	4	6	8	10	12	14	16	18	20	22	
Common Offset Bends	15°	MAX CONDUIT SIZE	3/4	1-1/2	2								
		CENTER TO CENTER	7-3/4	15-7/16	23-3/16	30-15/16	38-5/8	46-3/8	54-1/16	61-13/16	69-9/16	77-1/4	85
	30°	MAX CONDUIT SIZE		3/4	1	1-1/2	2						
		CENTER TO CENTER		8	12	16	20	24	28	32	36	40	44
	45°	MAX CONDUIT SIZE			1/2	1	1-1/4	1-1/2	2				
		CENTER TO CENTER			8-1/2	11-15/16	14-1/8	16-15/16	19-13/16	22-5/8	25-7/16	28-1/4	31-1/8



## Layout For an Offset Bend (cont'd)

### Calculating "Shrink"

When making offsets, it is common practice to make the offset as close to the obstruction as possible. When laying out an offset and working away from an obstruction, no special provisions are required. However, when approaching an obstruction, the conduit "shrinks."

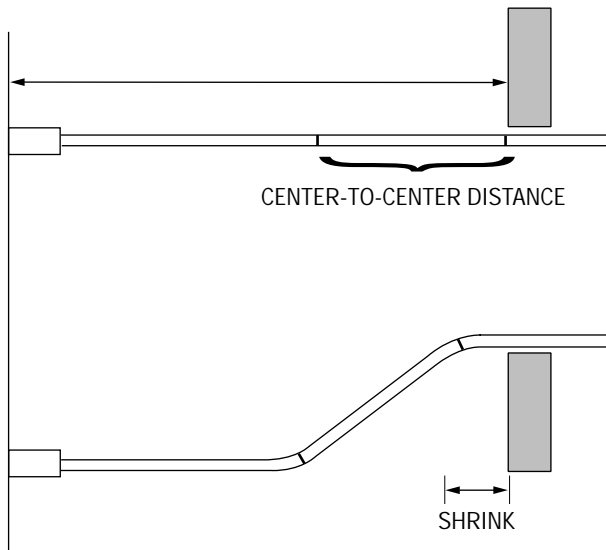

To get the second bend closer to the obstruction, both bends must be adjusted forward. The amount of this adjustment is referred to as *shrink*. The following illustration shows the same installation with shrink factored in.

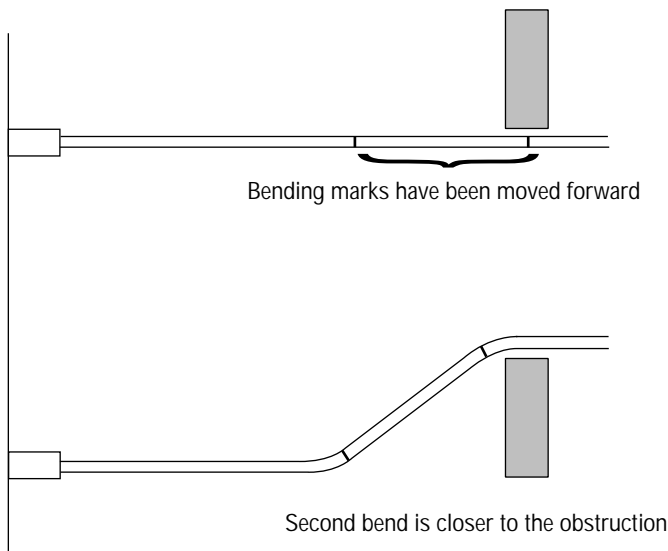

To find the center-to-center distance and the amount of shrink per inch of depth for a particular offset, consult the Greenlee Offset Multiplier and Shrink Table.

### Greenlee Offset Multiplier and Shrink Table

Offset Angle	Multiplier	Shrink per inch of Offset Depth
10°	6.0	1/16"
15°	3.86	1/8"
22-1/2°	2.6	3/16"
30°	2.0	1/4"
45°	1.4	3/8"
60°	1.2	1/2"

To use this table: Determine the depth of the offset and the degree of bend. Calculate the center-to-center distance by multiplying the amount of the offset by the multiplier (center column). Calculate the amount of shrink by multiplying the shrink per inch of offset depth (rightmost column) by the offset depth.

Example: 6-inch offset  
30-degree bend

Multiplier for 30°: 2

Multiply the amount of offset by the multiplier to find the center-to-center distance:  $2 \times 6 = 12$

Find the amount of shrink per inch of offset in the table: 1/4"

Multiply the shrink per inch by the amount of the offset:  $6 \times 1/4" = 1.5$  inches

Mark the conduit: Place the second bending mark 1.5 inches past the obstruction; measure back toward the starting point and place the first bending mark 12 inches before the second bending mark.

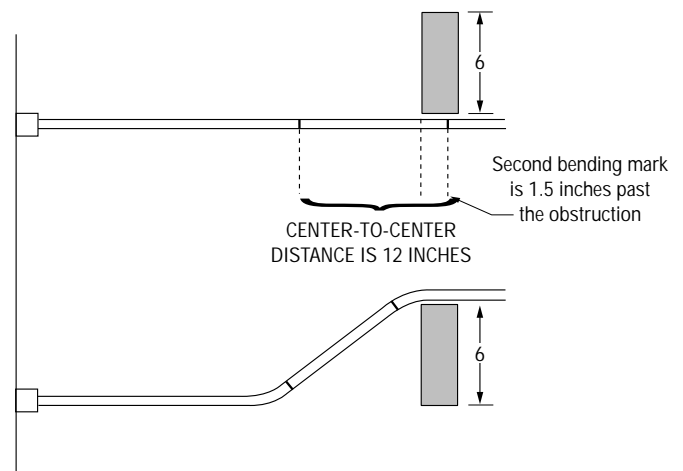

## Laying Out a Segment Bend

When a bend with a large radius is necessary, segment bending is required. Segment bending requires a series of small bends, or shots, spaced closely together.

Use the formulas and tables that follow to mark the conduit. To easily and accurately make the bend, use a model 1802 Bending Table or a model 1807 Bending Degree Indicator.

1. Determine the size of conduit to be used, the length of stub needed, the degree of the bend, and the bending radius.

*Example:*      2" conduit      90° bend  
                     60" stub      46" radius

2. Find the total length of conduit needed, which is the *developed length*. Use the Developed Length Formula or, for a 90-degree bend, use the Developed Length for 90-Degree Bend Table.

*Example:*      90° bend, 46"  
*Formula:*       $0.01744 \times 90 \times 46 = 72.2$   
*Table:*          72.22

3. Find the location of the center of the bend and mark the conduit. To find the location, see To Locate the Center of a 90-Degree Bend.

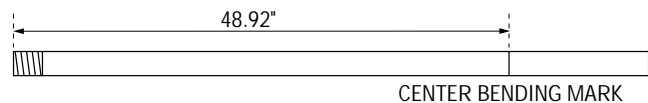

4. Refer to the Suggested Number of Bends Table. Based on the radius, find an appropriate number of bends. This is usually an odd number.

*Developed Length:*      72.22  
*Number of Bends:*      15

5. Divide the developed length by the number of bends to find the distance between each bend.

*Distance Between Bends:*       $72.22/15 = 4.81$   
*Round to the Nearest*  
*Fraction or Whole Number:*      4-13/16

6. Mark the conduit.

*Place marks 4-13/16" apart*



7. Use the Ram Travel Constants Table to find the approximate amount of ram travel per bend.

*Ram Travel Constant:*      6.2  
*Number of Bends:*      15  
*Approximate Ram*  
*Travel Per Bend:*  $6.2 \div 15 = 0.41$  inches

8. Bend the conduit.

## Laying Out a Segment Bend (cont'd)

### Developed Length

Formula for Any Bend

$$\text{developed length} = 0.01744 \times \text{degree of bend} \times \text{bending radius}$$

**Developed Length Table**

		RADIUS - Increments by Ones									
		0	1	2	3	4	5	6	7	8	9
RADIUS - Increments by Tens	0	0	1.57	3.14	4.71	6.28	7.85	9.42	10.99	12.56	14.13
	10	15.70	17.27	14.84	20.41	21.98	23.85	25.12	26.69	28.26	29.83
	20	31.40	32.97	34.54	36.11	37.68	39.25	40.82	42.39	43.96	45.53
	30	47.10	48.67	50.24	51.81	53.38	54.95	56.52	58.09	59.66	61.23
	40	62.80	64.37	65.94	67.50	69.03	70.65	72.22	73.79	75.36	76.93
	50	87.50	80.07	81.64	83.21	84.78	86.35	87.92	89.49	91.06	92.63
	60	94.20	95.77	97.34	98.91	100.48	102.05	103.62	105.19	106.76	108.33
	70	109.90	111.47	113.04	114.61	116.18	117.75	119.32	120.89	122.46	124.03
	80	125.60	127.17	128.74	130.31	131.88	133.45	135.02	136.59	138.16	139.73
	90	141.30	142.87	144.44	146.01	147.58	149.15	150.72			

To use this table: Determine the developed length by finding the intersection of the appropriate row ("tens" digit of the radius) and appropriate column ("ones" digit of the radius).

Example: radius is 46 inches

Find the appropriate row: row labeled "40"

Find the appropriate column: column labeled "6"

Find the Developed Length at that intersection: 72.22

### To Locate the Center of a 90° Bend

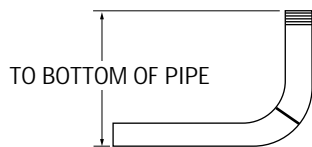

Measure and mark the length of the stub. Subtract the radius of the bend and 1/2 of the O.D of the pipe. Add 1/2 of the developed length.

Example: 60" stub 46" radius 90° bend

Developed Length:  $0.01744 \times 90 \times 46 = 72.2$

1/2 of Developed Length:  $72.2 \times 1/2 = 36.1$

Center Mark:  $60 - 46 - 1.18 + 36.1 = 48.92$

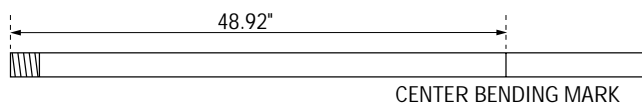

**Laying Out a Segment Bend (cont'd)**

**Suggested Number of Bends Table**

Radius	Suggested Number of Bends*	
	(minimum)	(maximum)
4" - 10"	2	3
10" - 20"	3	5
20" - 30"	5	9
30" - 40"	9	13
40" - 50"	13	19
50" - 60"	19	25

\*The minimum and maximum number of bends are suggestions only. Using a larger number of bends will produce a smoother segment bend.

**Ram Travel Constants Table**

Conduit or Pipe Size	1/2"	3/4"	1"	1-1/4"	1-1/2"	2"	2-1/2"	3"	3-1/2"	4"
"D"	5.2	5.2	5.2	5.2	5.2	6.2	7.1	8.1	9.1	10.2

To use this table: Find the conduit or pipe size in the top row, and find the constant "D" that corresponds to that size. Divide constant "D" by the number of bends to be made. The result is the amount of ram travel per bend required AFTER the shoe contacts the conduit or pipe.

**Outside Diameter of Galvanized Rigid Conduit or Schedule 40 Pipe**

OUTSIDE DIAMETER PIPE AND RIGID CONDUIT			ONE-HALF THE OUTSIDE DIAMETER	
SIZE	O.D.	FRACTION	O.D.	FRACTION
1/2" =	0.840 =	27/32	0.420 =	27/64
3/4" =	1.050 =	1-3/64	0.525 =	17/32
1" =	1.315 =	1-5/16	0.658 =	21/32
1-1/4" =	1.660 =	1-21/32	0.830 =	53/64
1-1/2" =	1.900 =	1-29/32	0.950 =	61/64
2" =	2.375 =	2-3/8	1.187 =	1-3/16
2-1/2" =	2.875 =	2-7/8	1.437 =	1-7/16
3" =	3.500 =	3-1/2	1.750 =	1-3/4
3-1/2" =	4.000 =	4	2.000 =	2
4" =	4.500 =	4-1/2	2.250 =	2-1/4
5" =	5.562 =	5-9/16	2.786 =	2-25/32
6" =	6.625 =	6-5/8	3.312 =	3-5/16

**Gain Factor Table**

		ANGLE - Increments by Ones									
		—	1°	2°	3°	4°	5°	6°	7°	8°	9°
ANGLE - Increments by Tens	0°	.0000	.0000	.0000	.0000	.0000	.0000	.0001	.0001	.0003	.0003
	10°	.0005	.0006	.0008	.0010	.0013	.0015	.0018	.0022	.0026	.0031
	20°	.0036	.0042	.0048	.0055	.0062	.0071	.0079	.0090	.0100	.0111
	30°	.0126	.0136	.0150	.0165	.0181	.0197	.0215	.0234	.0254	.0276
	40°	.0298	.0322	.0347	.0373	.0400	.0430	.0461	.0493	.0527	.0562
	50°	.0600	.0637	.0679	.0721	.0766	.0812	.0860	.0911	.0963	.1018
	60°	.1075	.1134	.1196	.1260	.1327	.1398	.1469	.1544	.1622	.1703
	70°	.1787	.1874	.1964	.2058	.2156	.2257	.2361	.2470	.2582	.2699
	80°	.2819	.2944	.3074	.3208	.3347	.3491	.3640	.3795	.3955	.4121
	90°	.4292	—	—	—	—	—	—	—	—	—

To use this table: Find the gain factor by finding the intersection of the appropriate row ("tens" digit of the angle) and appropriate column ("ones" digit of the angle). See example below.

Example:           64° bend  
                       15-inch center line radius

Correct row:       row labeled "60°"

Correct column:   column labeled "4°"

Gain Factor:       0.1327

Gain for total bend:  $0.1327 \times 15 = 1.9905$   
                           round up to nearest whole  
                           number or common fraction

Gain for total bend: 2"

**Correcting Overbends**

A reverse bending shoe, model number 10947, is available for correcting overbends.

*Note: If using an electric pump, disconnect the pump from the power supply before changing accessories.*

1. Remove shoe and shoe support from the ram.
2. Attach the reverse bending shoe to the ram (A) with the shoe pin (J). (See the illustration under Setup in this manual.)
3. Remove the pipe support pins (H). Move the pipe supports to the two unmarked holes in the frame. Orient the pipe support so that the side of the pipe support facing the conduit corresponds to the size of the conduit. Install the two pipe support pins and turn the thumb screws clockwise.
4. Place the conduit into the bender as illustrated.

*Note: If using an electric pump, connect the pump to the power supply.*

5. Use the hydraulic pump to advance the ram.

**880 Hydraulic Bender—Exploded View and Parts List**

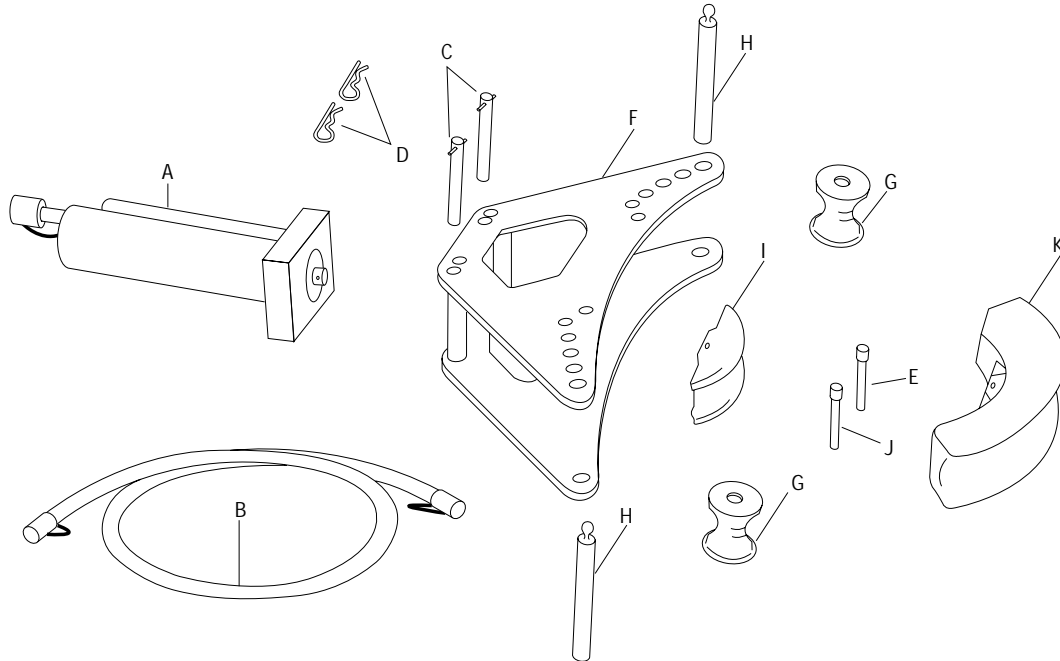

Key	Catalog No.	Part No.	Description	Qty
A	747	501 6249.7	15-Ton Ram with 4018GB female quick coupler (includes Keys C-E)	1
B	1 1289	501 1289.9	3/8" x 6' High Pressure Hose with two 4033GB male quick couplers	1
C	1 5289	501 5829.5	Cylinder head pin (D)	2
D	2725AA	905 0302.3	Spring Clip	2
E	1 0826	501 0826.3	Ram Pin	1
F	2345AA	500 3396.4	Frame unit	1
G	2349AA	500 3400.6	Pipe support	2
H	1 3679	501 3679.8	Pipe support pin	2
I	1 0939	501 0939.1	Small shoe support (1/2" thru 2")	1
J	1 0826	501 0826.3	Shoe pin	1
K			<b>90° Aluminum Bending Shoes</b>	
	1 0919	501 0919.7	1" Shoe — 5-3/4" centerline radius	
	1 0920	501 0920.0	1-1/4" Shoe — 7-1/4" centerline radius	
	1 0921	501 0921.9	1-1/2" Shoe — 8-1/4" centerline radius	
M	14909	501 4909.1	Steel Storage Box (not shown)	
			<b>Optional Shoes</b>	
			<b>90° Aluminum Bending Shoes</b>	
	1 0917	501 0917.0	1/2"	
	1 0918	501 0918.9	3/4"	
	1 0947	501 0947.2	Shoe	
			<b>90° Aluminum Bending Shoes of 40 Mil PVC Coated Rigid Conduit</b>	
	33456	503 3456.5	1/2" Shoe — 4" centerline radius	
	33457	503 3457.3	3/4" Shoe — 4-1/2" centerline radius	
	33458	503 3458.1	1" Shoe — 5-3/4" centerline radius	
	33459	503 3459.0	1-1/4" Shoe — 7-1/4" centerline radius	
	33463	503 3463.8	1-1/2" Shoe — 8-1/4" centerline radius	
	33462	503 3462.0	2" Shoe — 9-1/2" centerline radius	
			<b>90° Ductile Iron Bending Shoes for Bending Schedules 40 and 80 Pipe</b>	
	18764	501 8764.3	1" Shoe — 5-3/4" centerline radius	
	18746	501 8743.0	1-1/4" Shoe — 7-1/4" centerline radius	
	18745	501 8745.7	1-1/2" Shoe — 8-1/4" centerline radius	
	18747	501 8747.3	2" Shoe — 9-1/2" centerline radius	

**2345AA Frame Unit (500 3396.4)—Parts List**

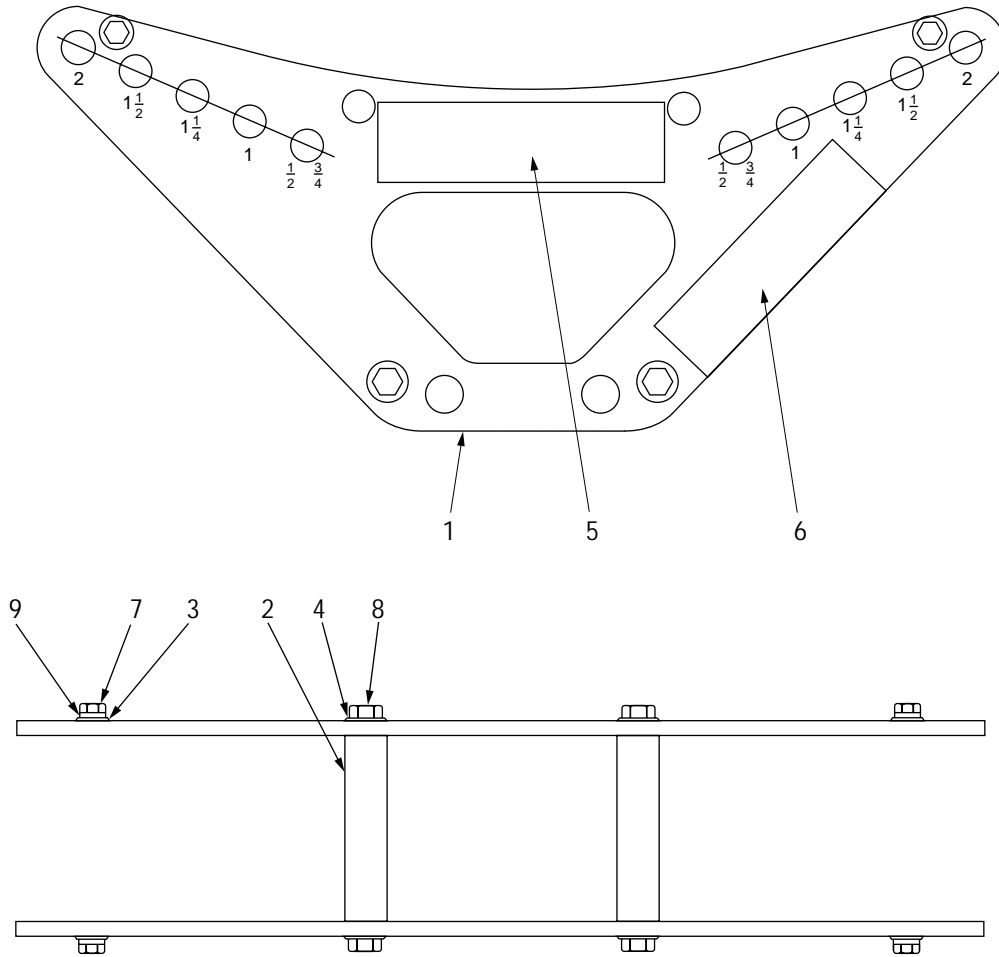

Key	Cat. No.	Part No.	Description	Qty
1	2326AA	500 3368.9	Aluminum Cross Plate .....	2
2	2327AA	500 3369.7	Frame Support Pin .....	2
3	1312AV	500 2767.0	Washer, 3/8 x 13/16 x 1/16, flat .....	4
4	1313AV	500 2768.9	Washer, 7/16 x 1 x 1/16, flat .....	4
5	21341	502 1341.5	Decal, Offset .....	1
6	22346	502 2346.1	Decal, Ram Travel .....	1
7	50381	905 0381.3	Screw, 3/8-16 x 1/2 hex head cap .....	4
8	1823GB	905 0540.9	Screw, 7/16-14 x 1 hex head cap .....	4
9	3666GB	905 0743.6	Washer, 3/8 x 5/8 lock .....	4
10	343165	503 4316.5	Decal, Read IM (not shown) .....	1

# 747-M4 Ram (501 6249.7)—Parts List

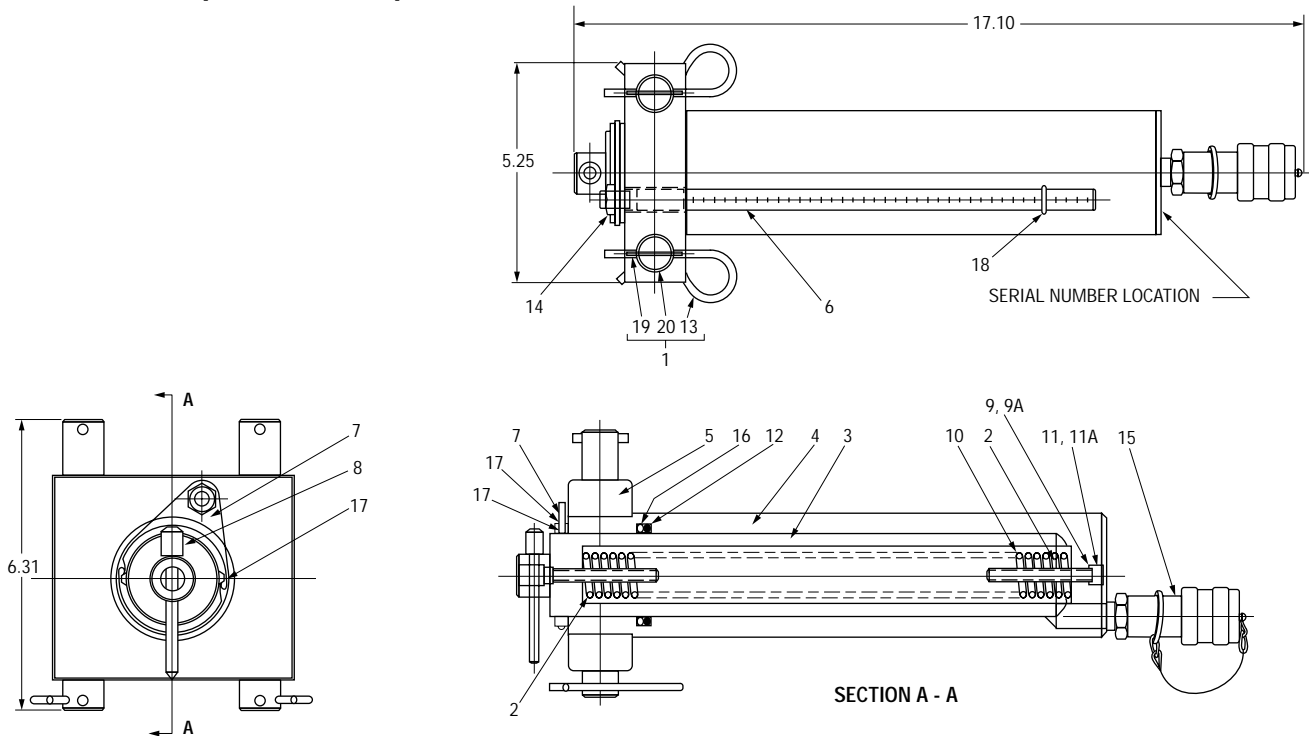

Key	Cat. No.	Part No.	Description	Qty
1	15829	501 5829.5	Pin unit, cylinder block (consists of parts 13, 19 & 20) .....	2
2	2551AA	500 3477.4	Retainer, spring .....	2
3	16250	501 6250.0	Piston .....	1
4	16251	501 6251.9	Cylinder .....	1
5	16252	501 6252.7	Block, cylinder .....	1
6	21946	502 1946.4	Scale, piston .....	1
7	21947	502 1947.2	Bracket, scale .....	1
8	10826	501 0826.3	Pin, 1/4 x 3-1/2 .....	1
* 9	03420	500 3420.0	Washer, nylon, .321 x .428 x .040 .....	2
9A	13496	501 3496.5	Washer, nylon, .321 x .460 x .040 .....	2
10	2549AA	500 3475.8	Spring, tension .....	1
* 11	11341	501 1341.0	Screw, spring retainer .....	2
11A	01717	500 1717.9	Screw, spring, retainer .....	2
12	4060GB	905 0068.7	O-Ring, 2 x 2-3/8 x 3/16 .....	1
13	50302	905 0302.3	Clip, hitch pin .....	2
14	4090GB	905 0848.3	Nut, 3/8-24 x 3/16 steel light jam .....	1
15	4018GB	905 0807.6	Coupler, 3/8 female quick .....	1
16	4045GB	905 0832.7	Backup ring, 2 x 2-3/8 x 3/16 .....	1
17	4593GB	905 0895.5	Ring, truarc retaining .....	4
18	52867	905 2867.0	O-Ring, 7/32 x 5/8 x 3/32 .....	1
19	50422	905 0422.4	Roll pin, 7/32 x 1-3/8 .....	1
20	540AV	500 4071.5	Pin, cylinder .....	1
		501.3796.4	Packing Kit, repair (contains 9, 12, and 16)	

\* Nylon washer (9) and spring retainer screw (11) are for cylinders built prior to December 1996. 9A and 11A are for units built since December 1996. Use 9A and 11A if possible.

## GREENLEE TEXTRON

Greenlee Textron / Subsidiary of Textron Inc.

4455 Boeing Drive, Rockford, IL 61109-2988 USA

General Offices: 815/397-7070

Customer Center and Field Service: 800/435-0786

Fax (24 Hour) Customer Center: 800/451-2632 • 815/397-1865

Canada Fax (24 Hour) Customer Center: 800/524-2853

Printed in the U.S.A.