

Instruction Manual
for AC Compressors
English

XAS 185 KD7 T4

Engine Kubota V2403

Instruction Manual for AC Compressor

XAS 185 KD7 T4

Original instructions

Printed matter Nr
1310 3013 85

09/2014



ATLAS COPCO - PORTABLE ENERGY DIVISION
www.atlascopco.com

Warranty and Liability Limitation

Use only authorized parts.

Any damage or malfunction caused by the use of unauthorized parts is not covered by Warranty or Product Liability.

The manufacturer does not accept any liability for any damage arising from modifications, additions or conversions made without the manufacturer's approval in writing.

Neglecting maintenance or making changes to the setup of the machine can result in major hazards, including fire risk.

While every effort has been made to ensure that the information in this manual is correct, Atlas Copco does not assume responsibility for possible errors.

Copyright 2014, Atlas Copco.

Any unauthorized use or copying of the contents or any part thereof is prohibited.

This applies in particular to trademarks, model denominations, part numbers and drawings.

Preface

Please read the following instructions carefully before starting to use your compressor.

It is a solid, safe and reliable machine, built according to the latest technology. Follow the instructions in this booklet and we guarantee you years of troublefree operation.

Always keep the manual available near the machine.

In all correspondence always mention the compressor type and serial number, shown on the data plate.

The company reserves the right to make changes without prior notice.

Table of contents

1	Safety precautions for portable compressor	7
1.1	Introduction	7
1.2	General safety precautions	7
1.3	Safety during use and operation	8
1.4	Safety during maintenance and repair	9
1.5	Tool applications safety	9
1.6	Batteries	9
1.7	Ether fuel Systems	10
1.8	Pressure vessels	10
1.9	Safety valves	10
1.10	Injury Prevention	10
2	Leading particulars	12
2.1	Description of Safety Pictograms Used in this Manual	12
2.2	General description	12
2.3	Main Parts	14
2.4	Air flow	18
2.5	Oil system	18
2.6	Continuous regulating system	18
2.7	Electric system	20
2.7.1	Circuit Diagram	20
3	Operating instructions	22
3.1	Parking, towing and lifting instructions	22
3.1.1	Drawbar Preparations for Towing	22
3.2	StartiNg / Stopping	23
3.2.1	Overview Icons	24
3.2.2	Starting	27
3.2.3	Stopping	31
3.2.4	Shutdown	32
3.2.5	Power Off	32
3.2.6	Diesel Particulate Filter regeneration	32
3.2.7	Automatic Dpf Regeneration (Default)	33
3.2.8	Inhibit Dpf Regeneration	33
3.2.9	Increasing Soot Load	33
3.2.10	Turning Regeneration Back To Auto	34
3.2.11	Force Dpf Regeneration	34
3.2.12	Service Regeneration	34
3.2.13	Settings	34
3.2.14	Fault Codes	36
3.2.15	Emergency Stop	39
3.2.16	Parking Instructions	40
3.2.17	Towing Instructions	40
3.2.18	Lifting Instructions	40
3.3	Before Starting	40
4	Maintenance	41
4.1	Use Of Service Paks	41
4.2	Preventive Maintenance Schedule For The Compressor	41
5	Technical Specifications	42
5.1	Reference Conditions	42
5.2	Limitations	42
5.3	Altitude Unit Performance Curve	43
5.4	Performance Data	44
5.5	Design Data	44
5.5.1	Compressor	44
5.5.2	Engine	44
5.5.3	Unit	44
5.6	Lubrication Oils	46
5.6.1	Check Engine Oil Level	47
5.6.2	Check Compressor Oil Level	47
5.6.3	Engine Oil And Oil Filter Change	47
5.6.4	Compressor Oil And Oil Filter Change	47
5.7	Cleaning Coolers	48
5.8	Battery Care	48
5.8.1	Electrolyte	48
5.8.2	Recharging A Battery	48
5.8.3	Battery Maintenance	48
5.9	Storage	48
5.10	Service Kits	48

CALIFORNIA Proposition 65 Warning

Diesel engine exhaust and some of its constituents are known to the State of California to cause cancer, birth defects, and other reproductive harm.

6	Adjustments And Servicing Procedures ...	49
6.1	Adjustment Of The Continuous Regulating System	49
6.2	Air Filter Engine/compressor	50
6.2.1	Main Parts	50
6.2.2	Cleaning The Dust Trap	50
6.2.3	Replacing The Air Filter Element	50
6.3	Air Receiver	51
6.4	Safety Valve	51
6.5	Fuel System	51
7	Problem Solving	52
7.1	Problem Solving Chart	52
7.2	Alternator Precautions	52
8	Maintenance Log	54
9	Maintenance Log	55

Safety precautions for portable compressor



To be read attentively and acted accordingly before towing, lifting, operating, performing maintenance or repairing the compressor.

Introduction

The policy of Atlas Copco is to provide the users of their equipment with safe, reliable and efficient products.

Factors taken into account are among others:

- the intended and predictable future use of the products, and the environments in which they are expected to operate,
- applicable rules, codes and regulations,
- the expected useful product life, assuming proper service and maintenance,

Before handling any product, take time to read the relevant instruction manual. Besides giving detailed operating instructions, it also gives specific information about safety, preventive maintenance, etc.

These precautions are general and some statements will therefore not always apply to a particular unit.

When handling, operating, overhauling and/or performing maintenance or repair on Atlas Copco equipment, the mechanics are expected to use safe engineering practices and to observe all relevant local safety requirements and ordinances. The following list is a reminder of special safety directives and precautions mainly applicable to Atlas Copco equipment.

This brochure applies to machinery processing or consuming air. Processing of any other gas requires additional safety precautions typical to the application and are not included herein.

All responsibility for any damage or injury resulting from neglecting these precautions or by non-observance of ordinary caution and due care required in handling, operating, maintenance or repair, also if not expressly mentioned in this instruction manual, is disclaimed by Atlas Copco.

If any statement does not comply with local legislation, the stricter of the two shall be applied. Statements in this manual should not be interpreted as suggestions, recommendations or inducements that it should be used in violation of any applicable laws or regulations.

General safety precautions

- 1 The owner is responsible for maintaining the unit in a safe operating condition. Unit parts and accessories must be replaced if missing or unsuitable for safe operation.
- 2 Use only lubricating oils and greases recommended or approved by Atlas Copco or the machine manufacturer. Ascertain that the selected lubricants comply with all applicable safety regulations, especially with regard to explosion or fire risk and the possibility of decomposition or generation of hazardous gases.
- 3 The supervisor, or the responsible person, shall at all times make sure that all instructions regarding machinery and equipment operation and maintenance are strictly followed and that the machines with all accessories and safety devices, as well as the consuming devices, are in good repair, free of abnormal wear or abuse, and are not tampered with.
- 4 Maintenance, overhaul and repair work shall only be carried out by adequately trained personnel; if required, under supervision of someone qualified for the job.
- 5 Whenever there is an indication or any suspicion that an internal part of a machine is overheated, the machine shall be stopped but no inspection covers shall be opened before sufficient cooling time has elapsed; this to avoid the risk of spontaneous ignition of oil vapour when air is admitted.
- 6 Maintenance work, other than routine attention, shall only be undertaken when the machine is turned off.
- 7 Before dismantling any pressurized component, the compressor or the equipment shall be effectively isolated from all sources of pressure and be completely vented to atmosphere. In addition, a warning sign bearing a legend such as "work in progress; do not open" shall be attached to each of the isolating valves.
- 8 Before a machine is being repaired, steps shall be taken to prevent inadvertent starting. In addition, a warning sign bearing a legend such as "work in progress; do not start" shall be attached to the starting equipment. The battery shall be disconnected and removed or the terminals covered by insulating caps.
- 9 Normal ratings (pressures, temperatures, speeds, etc.) shall be durably marked.
- 10 Never operate a machine or equipment beyond its rated limits (pressure, temperature, speed, etc.).
- 11 Maintenance and repair work should be recorded in an operator's logbook for all machinery. Frequency and nature of repairs can reveal unsafe conditions.
- 12 The machinery and pneumatic equipment shall be kept clean, i.e. as free as possible from oil, dust or other deposits.
- 13 To prevent an increase in working temperature, inspect and clean heat transfer surfaces (cooler fins, intercoolers, water jackets, etc.) regularly. For every machine establish a suitable time interval for cleaning operations.
- 14 All regulating and safety devices shall be maintained with due care to ensure that they function properly. They may not be bypassed.
- 15 Care shall be taken to avoid damage to safety valves and other pressure relief devices, especially to avoid plugging by paint, oil coke or dirt accumulation, which could interfere with the functioning of the device.
- 16 Pressure and temperature gauges shall be checked regularly with regard to their accuracy. They shall be replaced whenever outside acceptable tolerances.
- 17 Parts shall only be replaced by genuine Atlas Copco replacement parts.
- 18 Safety devices shall be tested as described in the maintenance schedule of the instruction book(s) to determine that they are in good operating condition.
- 19 Never use flammable solvents or carbon tetrachloride for cleaning parts. Take safety precautions against toxic vapors when cleaning parts in or with cleaning products.
- 20 Observe scrupulous cleanliness during maintenance and repair. Keep away dirt by covering the parts and exposed openings with clean cloth, paper or tape.
- 21 Protect the engine, alternator, air intake filter, electrical and regulating components, etc. to prevent moisture ingress, e.g. when steam-cleaning.

- 22 When performing any operation involving heat, flames or sparks on a machine, the surrounding components shall first be screened with non-flammable material.
- 23 Never use a light source with open flame for inspecting the interior of a machine, pressure vessel, etc.
- 24 On portable units, support the drawbar and axle(s) securely if working underneath the units or when removing a wheel. Do not rely on jacks.
- 25 Prior to stripping a compressor, engine or other machine or undertaking major overhaul on it, prevent all movable parts with a mass exceeding 15 kg (30 lbs) from rolling over or moving.
- 26 When repair has been completed, make sure that no tools, loose parts or rags are left in, or on, the machine, the prime mover or the driving gear. The machine shall be barred several revolutions to ensure that there is no mechanical interference within the machine or driver.

Safety during use and operation

To lift a unit, all loose or pivoting parts, e.g. doors shall first be securely fastened. Do not attach cables, chains or ropes directly to the lifting eye; apply a crane hook or lifting shackle meeting local safety rules.

Helicopter lifting using the lifting eye is forbidden.

It is strictly forbidden to dwell or stay in the risk zone under a lifted load. Never lift the unit over people or residential areas.

Lifting acceleration and retardation shall be kept within safe limits.

1 Before towing the unit:

- ascertain that the pressure vessel is depressurized,
- check the drawbar, the brake system and the towing eye. Also check the coupling of the towing vehicle,
- check that the pivot wheel or stand leg is safely locked in the raised position,
- ascertain that the towing eye can swivel freely on the hook,
- check that the wheels are secure and that the tires are in good condition and inflated correctly,
- connect the signal cable, check all lights and connect the pneumatic brake couplers,
- attach the safety break-away cable to the towing vehicle,
- remove wheel chocks, if applied, and disengage the parking brake.

- Apply safety chains to tow vehicle.
- 2 If the unit is to be backed up by the towing vehicle, disengage the overrun brake mechanism (if equipped).
 - 3 Never exceed the maximum towing speed of the unit.
 - 4 Place the unit on level ground and chock the wheels before disconnecting the unit from the towing vehicle. Unclip the safety break-away cable
 - 5 When the unit has to operate in a fire-hazardous environment, each engine exhaust has to be provided with a spark arrestor to trap incendiary sparks.
 - 6 The exhaust contains carbon monoxide which is a lethal gas. When the unit is used in a confined space, conduct the engine exhaust to the outside atmosphere by a pipe of sufficient diameter (min. 4 inches); do this in such a way that no extra back pressure is created for the engine. If necessary, install an extractor.
 - 7 When operating in a dust-laden atmosphere, place the unit so that dust is not carried towards it by the wind. Operation in clean surroundings considerably extends the intervals for cleaning the air intake filters and the cores of the coolers.
 - 8 Locate the unit away from walls. Take all precautions to ensure that hot air exhausted from the engine and driven machine cooling systems cannot be recirculated. If such hot air is taken in by the engine or driven machine cooling fan, this may cause overheating of the unit; if taken in for combustion, the engine power will be reduced.
 - 9 No external force may be exerted on the air outlet valves, e.g. by pulling on hoses or by installing auxiliary equipment directly to a valve, e.g. a water separator, a lubricator, etc.
 - 10 Distribution pipework and air hoses must be of correct size and suitable for the working pressure. Never use frayed, damaged or deteriorated hoses. Replace hoses and flexibles of which the lifetime expired. Use only the correct type and size of hose end fittings and connections. Install safety pins on quick type hose connections. A hose connected to a 2 inch (50 mm) valve must be provided with a safety wire (8 mm) fixed to the hose for effective pressures as from 145 psi (10 bar) up, although it is recommended to apply such safeguard already from (60 psi) 4 bar up.
- The safety wire ends have to be attached, one to the eye provided next to the compressor air outlet valve, the other one to a point near to the air inlet of the applied

equipment. Finally a wire mesh hose can be fixed over the hose ends to dampen the blast in case a connection starts leaking or should become undone.

Close the compressor air outlet valve before connecting or disconnecting a hose. Ascertain that a hose is fully depressurized before disconnecting it.

When blowing through a hose or air line, ensure that the open end is held securely. A free end will whip and may cause injury.

Never play with compressed air. Never apply it to your skin or direct an air stream at people. Never use it to clean dirt from your clothes. When using it to clean down equipment, do so with extreme caution and use eye protection.

- 11 Never move a unit when external lines or hoses are connected to the outlet valves, to avoid damage to valves and/or manifold and hoses.
- 12 Never refill fuel while the unit is running. Keep fuel away from hot parts such as air outlet pipes or the engine exhaust. Do not smoke when fueling. When fueling from an automatic pump, a ground cable should be connected to the unit to discharge static electricity. Never spill nor leave oil, fuel, coolant or cleansing agent in or around the unit.
- 13 Never operate the unit in surroundings where there is a possibility of taking in flammable or toxic fumes.
- 14 Never operate the unit at pressures or speeds below or in excess of the limit ratings stated on the Principal Data sheet.
- 15 On water-cooled engines with closed cooling circuit: allow the unit to cool before removing a pressure cap.
- 16 All doors shall be shut during operation so as not to disturb the cooling air flow inside the body-work and/or render the silencing less effective. A door should be kept open for a short period only, e.g. for inspection or adjustment
- 17 Wear ear protectors when environmental noise can reach or exceed 85 dB(A). Beware of long-time exposure to noise.
- 18 Periodically check that:
 - all safety equipment is in good working order,
 - all guards and air conducting baffles are in place and securely fastened,

- all hoses and/or pipes inside the unit are in good condition, secure and not rubbing,
- there are no fuel, oil or coolant leaks,- all fasteners are tight
- all electrical leads are secure and in good order,
- the engine exhaust system is in good condition,
- air outlet valves and manifold, hoses, couplings, etc. are in good repair, free of wear or abuse,
- the wheel nuts are tightened to the proper torque.

When more than one compressor is connected to a common header, be sure each compressor has a non-return valve (check valve) to prevent reverse rotation when stopping.

Safety during maintenance and repair

Maintenance, overhaul and repair work shall only be carried out by adequately trained personnel; if required, under supervision of someone qualified for the job.

- 1 Use only the correct tools for maintenance and repair work, and only tools which are in good condition.
- 2 Parts shall only be replaced by genuine spare parts.
- 3 All maintenance work, other than routine attention, shall only be undertaken when the unit is stopped. Ensure that the unit cannot be started inadvertently
- 4 Before removing any pressurized component, the compressor or equipment shall be effectively isolated from all sources of pressure and the entire system shall be relieved of pressure. Do not rely on non-return valves (check valves) to isolate pressure systems.
- 5 Never use flammable solvents for cleaning (fire-risk). Take safety precautions against toxic vapours of cleaning liquids.
- 6 Scrupulously observe cleanliness during maintenance and when performing repairs. Keep dirt away by covering the parts and exposed openings with a clean cloth, paper or tape.
- 7 Never weld on or perform any operation involving heat near the fuel or oil systems. Fuel and oil tanks must be completely purged, e.g. by steam-cleaning, before carrying out such operations. Never weld on, or in any way modify, pressure vessels. Disconnect the alternator cables during arc welding on the unit.
- 8 Support the drawbar and the axle securely if working underneath the unit or when removing a wheel. Do not rely on jacks.
- 9 Make sure that no tools, loose parts or rags are left in or on the unit.

10 Before clearing the unit for use after maintenance or overhaul, check that operating pressures, temperatures and speeds are correct and that the control and shutdown devices function correctly.

11 Do not remove any of, or tamper with, the sound damping material. Keep the material free of dirt and liquids such as fuel, oil and cleansing agents.

12 Protect the electrical and regulating components, the air filter, etc. to prevent moisture from entering them, e.g. when steamcleaning.

Tool applications safety

Apply the proper tool for each job. With the knowledge of correct tool use and knowing the limitations of tools, along with some common sense, many accidents can be prevented.

Special service tools are available for specific jobs and should be used when recommended. The use of these tools will save time and prevent damage to parts.

- 1 Use only wrenches or sockets whose size fits the fastener.
- 2 Apply an open-end wrench only in the place of the fastener head, square to the thread axis.
- 3 Do not use a pipe or other improvised leverage extensions on handles.
- 4 Do not hammer on wrenches or other tools which are not specially designed for it.
- 5 Always support the ratchet head when using socket extensions.
- 6 Discard any wrench with broken or battered points or edges.
- 7 Never use hand type sockets on power or impact tools.
- 8 Select only heavy-duty impact sockets for use with pneumatic or electric impact tools.
- 9 Replace sockets showing cracks or wear; keep sockets clean.
- 10 Never use screwdrivers for prying, punching, chiseling, scoring or scraping.
- 11 Use the correct type and size of screwdriver for the job. The bit must match the fastener.
- 12 A screwdriver with rounded edges will slip; it needs to be redressed or discarded.
- 13 Never use a screwdriver or any other tool near a live

wire or electrical component. Plastic covering of handles is for comfort and grip only. They are not intended to act as insulation if such is not clearly marked by the manufacturer.

- 14 Never strike a hammer against a hardened object; use a soft drift against the object and strike against the drift.
- 15 Strike the object with the full face of the hammer.
- 16 Never use a hammer with a loose head.
- 17 Discard a hammer with chipped or mushroomed face.
- 18 Never use a chisel or punch with a chipped or mushroomed striking face.
- 19 Always pull on a wrench or socket handle, if possible, and adjust your stance to prevent a fall if something lets go.
- 20 Wear approved eye protection when using percussion tools or when scraping, chipping, shaving or grinding.
- 21 Wear protective gloves when holding a chisel or punch.

Batteries

When servicing batteries, always wear protecting clothing and glasses.

- 1 The electrolyte in batteries is a sulphuric acid solution which is fatal if it hits your eyes, and which can cause burns if it contacts your skin. Therefore, be careful when handling batteries, e.g. when checking the charge condition.
- 2 Install a sign prohibiting fire, open flame and smoking at the post where batteries are being charged.
- 3 When batteries are being charged, an explosive gas mixture forms in the cells and might escape through the vent holes in the plugs. Thus an explosive atmosphere may form around the battery if ventilation is poor, and can remain in and around the battery for several hours after it has been charged. Therefore:
 - never smoke near batteries being, or having recently been, charged,
 - never break live circuits at battery terminals, because a spark usually occurs.
- 4 When connecting an auxiliary battery (AB) in parallel to the unit battery (CB) with booster cables: connect the + pole of AB to the + pole of CB, then connect the - pole of CB to the mass of the unit. Disconnect in the reverse order. *Incorrect connection will damage alternator.*

Ether fuel Systems

Ether fuel systems are used for diesel cold starting.

- 1 Do not use ether as a starting aid in conjunction with other starting aids (i.e. glow plug, air intake heater etc.) as an explosive condition may result in severe engine damage or personal injury.
- 2 This type of fuel is extremely flammable, toxic and poisonous. Avoid contact with eyes or skin and breathing the fumes. If accidentally swallowed, do not induce vomiting but call a physician immediately.
- 3 If fuel enters or fumes irritate the eyes, flush the latter with large quantities of clean water and call for medical aid.
- 4 Before operating ether cold starting aids, read the instructions and the container label.
- 5 Never operate ether cold starting aids while the engine is running as this can cause severe damage.
- 6 When maintenance, tests or repair has to be performed, do so in a well-ventilated area only, away from heat, open flame or sparks. Ascertain that the area is clearly marked out with signs prohibiting fire, open flame and smoking.
- 7 Wear eye protection when testing a system. Make sure that openings of a spray container, valve, tube or atomizer are pointed away from yourself and others while testing.
- 8 Do not store ether containers in temperatures above 160 °F (70°C),
- 9 Do not incinerate, puncture or attempt to remove the center core valve, side safety valve or any other part of an ether container.

Pressure vessels

Maintenance/installation requirements:

- 1 The vessel can be used as pressure vessel or as separator and is designed to hold compressed air for the following application:
 - pressure vessel for compressor,
 - medium AIR/OIL,and operates as detailed on the data plate of the vessel:
 - the maximum working pressure ps in psi (bar),
- 2 The pressure vessel is only to be used for the applications as specified above and in accordance with the technical specifications. Safety reasons prohibit any other applications.

- 3 National legislation requirements with respect to re-inspection must be complied with.
- 4 No welding or heat treatment of any kind is permitted to those vessel walls which are exposed to pressure.
- 5 The vessel is provided and may only be used with the required safety equipment such as manometer, overpressure control devices, safety valve, etc.
- 6 Draining of condensate shall be performed daily when vessel is in use.
7. Installation, design and connections should not be changed.
8. Bolts of cover and flanges may not be used for extra fixation.

Safety valves

All adjustments or repairs are to be done by an authorized representative of the valve supplier.

Following checks must be carried out:

- 1 A check of the opening of the lifting gear, 1 or 2 times a year. This can be done by lifting the ring or lever.
- 2 A check of the set pressure once a year according to the local regulations, if required. This check may not be done with the compressor supplying the air pressure and must be carried out on a proper test bench.

Injury Prevention

- 1 Stationary housing guards are provided on all rotating or reciprocating parts not otherwise protected and which may be hazardous to personnel. Machinery shall never be put into operation, when such guards have been removed, operate only when guards are securely reinstalled.
- 2 Do not open electrical cabinets, cubicles or other equipment while voltage is supplied. If such cannot be avoided, e.g. for measurements, tests or adjustments, have the action carried out by a qualified electrician only, with appropriate tools, and ascertain that the required bodily protection against electrical hazards is applied.
- 3 Noise, even at reasonable levels, can cause irritation and disturbance which, over a long period of time, may cause severe injuries to the nervous system of human beings.

When the sound pressure level, at any point where personnel normally has to attend, is:

- below 70 dB(A): no action needs to be taken,
 - above 70 dB(A): noise-protective devices should be provided for people continuously being present in the room,
 - below 85 dB(A): no action needs to be taken for occasional visitors staying a limited time only,
 - above 85 dB(A): room to be classified as a noise-hazardous area and an obvious warning shall be placed permanently at each entrance to alert people entering the room, for even relatively short times, about the need to wear ear protectors,
 - above 95 dB(A): the warning(s) at the entrance(s) shall be completed with the recommendation that also occasional visitors shall wear ear protectors,
 - above 105 dB(A): special ear protectors that are adequate for this noise level and the spectral composition of the noise shall be provided and a special warning to that effect shall be placed at each entrance.
- 4 Insulation or safety guards of parts the temperature of which can be in excess of 80 °C (175 °F) and which may be accidentally touched by personnel shall not be removed before the parts have cooled to room temperature.
 - 5 When hot parts have to be handled, e.g. shrink fitting, special heat-resistant gloves shall be used and, if required, other body protection shall be applied.
 - 6 If the working process produces fumes, dust or vibration hazards, etc., take the necessary steps to eliminate the risk of personnel injury.
 - 7 Before lifting machines, all loose parts which could be liable to fall down shall be removed or secured; pivoting parts such as doors, etc. shall be safely immobilized.
 - 8 To lift heavy parts, a hoist of ample capacity, tested and approved according to local safety regulations, shall be used.
 - 9 When lifting machinery, only hooks or shackles meeting local safety regulations shall be applied. Never shall cables, chains or ropes be applied directly on or through lifting eyes. Never allow sharp bends in lifting cables, chains or ropes.
 - 10 Lifting hooks, eyes, shackles, etc. shall never be bent and shall only have stress in line with their design load axis. The capacity of a lifting device diminishes when

- the lifting force is applied at an angle to its load axis.
- 11 For maximum safety and efficiency of the lifting apparatus all lifting members shall be applied as near to perpendicular as possible. If required, a lifting beam shall be applied between hoist, and load.
 - 12 When heavy parts are being lifted with a hoist, it is strictly forbidden to dwell or pass under the load or in the space which is liable to be hit if the load or part of it should topple over or come loose. Never leave a load hanging on a hoist. Lifting acceleration and retardation shall be kept within safe limits.
 - 13 A hoist has to be installed in such a way that the object will be lifted perpendicular. If that is not possible, the necessary precautions must be taken to prevent load-swinging, e.g. by using two hoists, each at approximately the same angle not exceeding 30deg from the vertical.
 - 14 When using compressed air or inert gas to clean down equipment, do so with caution and use the appropriate protection, at least safety glasses, for the operator as well as for any bystander. Do not apply compressed air or inert gas to your skin or direct an air or gas stream at people. Never use it to clean dirt from your clothes.
 - 15 Before blowing compressed air or inert gas through a hose, ensure that the open end is held securely, so that it cannot whip and cause injury.
 - 16 When washing parts in or with a cleaning solvent, provide the required ventilation and use appropriate protection such as a breathing filter, safety glasses, rubber apron and gloves, etc.
 - 17 Safety shoes should be compulsory in any workshop and if there is a risk, however small, of falling objects, wearing of a safety helmet should be included.
 - 18 If there is a risk of inhaling hazardous gases, fumes or dust, the respiratory organs must be protected and, depending on the nature of the hazard, so must the eyes and skin.
 - 19 Remember that where there is visible dust, the finer, invisible particles will almost certainly be present too; but the fact that no dust can be seen is not a reliable indication that dangerous, invisible dust is not present in the air.
 - 20 When using cartridge type breathing filter equipment, ascertain that the correct type of cartridge is used and that its useful service life is not surpassed.

Leading particulars

Description of Safety Pictograms Used in this Manual



This symbol draws your attention to dangerous situations. The operation concerned may endanger persons and cause injuries.



This symbol is followed by supplementary information.

General description

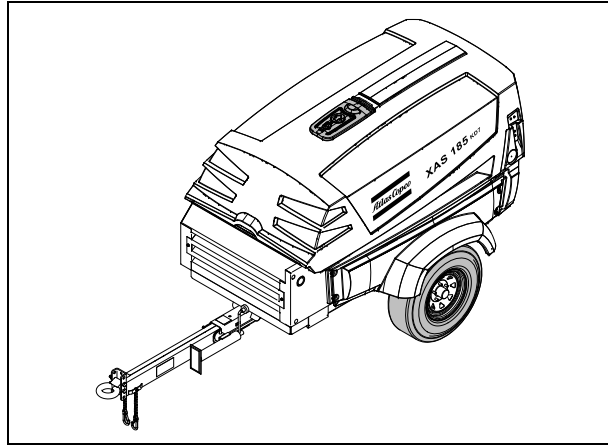

The XAS 185 KD7 is a silenced, single-stage, oil-injected screw compressor, built for an effective working pressure of 100 psi (7 bar).

Engine

The compressor is driven by a water-cooled diesel engine. The engine's power is transmitted to the compressor through a flexible coupling.

Compressor

The compressor casing houses two screw-type rotors, mounted on ball and roller bearings. The male rotor, driven by the engine, drives the female rotor. The male rotor has four lobes and the female rotor has six flutes. Thus, the male rotor revolves at 1 1/2 times the speed of the female rotor. The element delivers pulsation-free air. Injected oil is used for sealing, cooling and lubricating purposes.

Compressor oil system

The oil is boosted by air pressure. The system has no oil pump. The oil is removed from the air, in the air/oil vessel first by centrifugal force, second through the oil separator element. The vessel is provided with an oil level indicator.

Regulation

The compressor is provided with a continuous regulating system and a blow-down valve which is integrated in the unloader assembly. The valve is closed during operation by outlet pressure of the compressor element and opens by air receiver pressure when the compressor is stopped.

When the air consumption increases, the air receiver pressure will decrease and vice versa.

This receiver pressure variation is sensed by the regulating valve which, by means of control air to the unloader and engine speed regulator, matches the air output to the air consumption. The air receiver pressure is maintained between the pre-selected working pressure and the corresponding unloading pressure

Cooling system

Engine and compressor are provided with a radiator and oil cooler. The cooling air is generated by a fan, driven by the engine.

Safety devices

A thermal shut-down sensor protects the compressor against overheating. The air receiver is provided with a safety valve. The engine is equipped with low oil pressure and high coolant temperature shut-down sensors and an alternator/V-belt protection system.

Frame and axles

The compressor/engine unit is supported by rubber buffers in the frame.

The standard XAS 185 KD7 is equipped with an adjustable drawbar with a towing eye and road lighting.

As an option, the unit can be equipped with electric or hydraulic braking systems.

When driving backwards the hydraulic brake is not engaged automatically.

Bodywork

The bodywork has openings at the shaped front and rear end for the intake and outlet of cooling air and hinged doors for maintenance and service operations. The bodywork is internally lined with sound-absorbing material.

Lifting eye

A lifting eye is accessible through the roof panel at the top of the unit.

Control panel

The control panel grouping the air pressure gauge, control switch etc., is placed at the right hand/ rear of air compressor.

Data plate

The compressor is furnished with a data plate located on the front, drivers side of the unit showing the compressor type, serial number, maximum final pressure and normal working pressure.

PORTABLE AIR COMPRESSOR			
MANUFACTURED BY/FABRIQUE PAR: ATLAS COPCO COMPRESSORS LLC			
MODEL			
PRODUCT NUMBER			
MAX. FINAL PRESSURE, PSIG			
MANUFACTURED DATE			
			
TYPE OF VEHICLE/TYPE DE VEHICULE: TRA/REM			
GVWR/PNBV: _____ KG, V.I./N./N.I./V.I		PAINT: _____	
GAWR/PNBE KG	DIMENSION	COLD INFL. PRESS.	
TIRE/PNEU	RIM/JANTE	PRESS. DE GONFL. A FROID	
		PSI/LPC KPA	
<small>THIS VEHICLE CONFORMS TO ALL APPLICABLE STANDARDS PRESCRIBED UNDER THE CANADIAN AND U.S.A. MOTOR VEHICLE SAFETY REGULATIONS IN EFFECT ON THE DATE OF MANUFACTURE. CE VEHICULE EST CONFORME A TOUTES LES NORMES QUI LUI SONT APPLICABLES EN VERTU DU REGLEMENT SUR LA SECURITE DES VEHICULES AUTOMOBILES DU CANADA ET U.S.A. EN VIGUEUR A LA DATE DE SA FABRICATION.</small>			
<small>1310-0302 4B</small>			

Main Parts

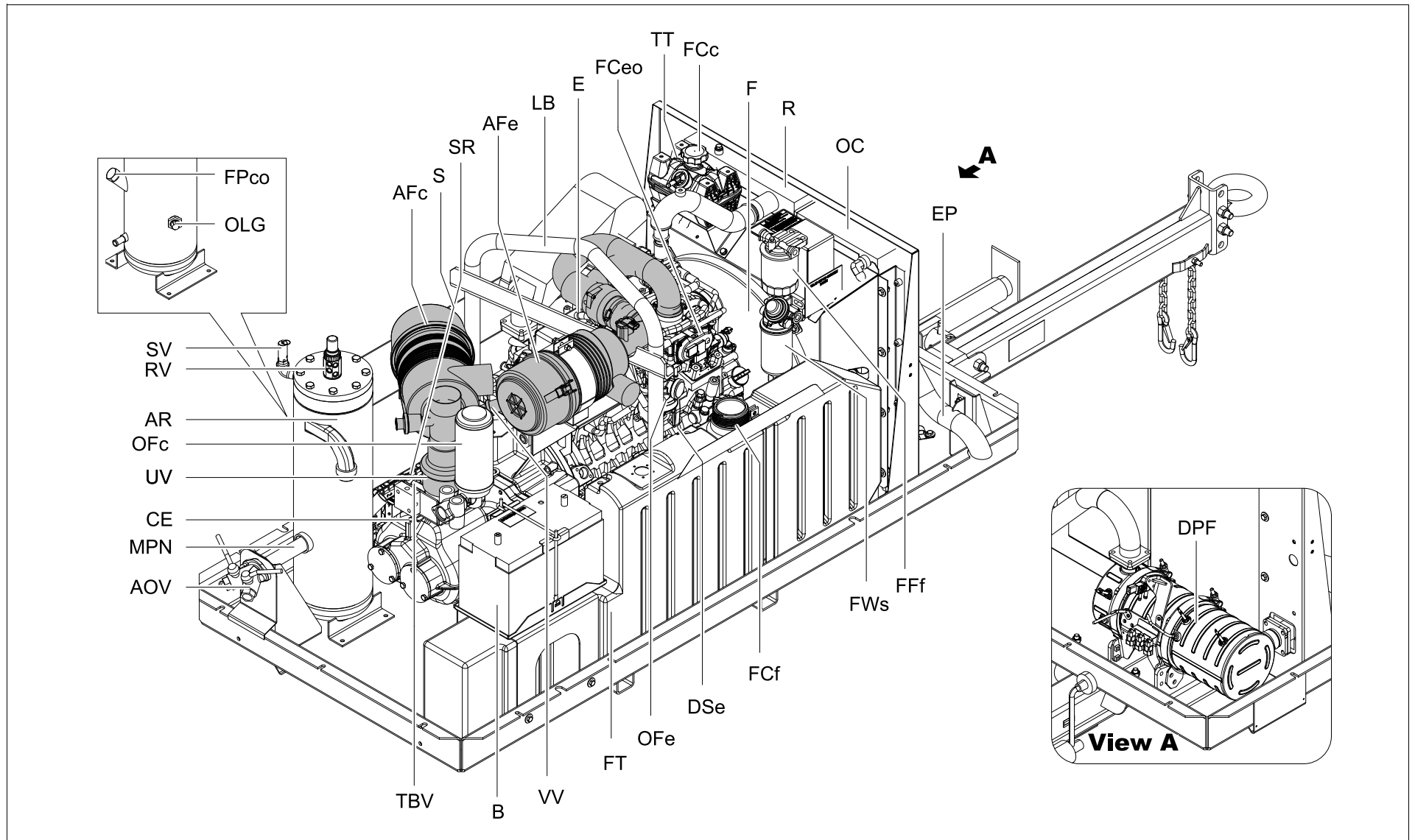

Reference	Name
AFc	Air Filter (Compressor element)
AFe	Air Filter (Engine)
AOV	Air Outlet Valves
AR	Air Receiver
B	Battery
CE	Compressor Element
DPF	Diesel Particulate Filter
DSe	Dip Stick Engine Oil
E	Engine
EP	Exhaust Pipe
F	Cooling Fan
FWs	Fuel Water Separator
FCc	Filler Cap (Coolant)
FCeo	Filler Cap (Engine Oil)
FCf	Filler Cap (Fuel)
FFf	Final Fuel Filter

Reference	Name
FT	Fuel Tank
FFp	Primary Fuel Filter
FPco	Compressor Oil Filling Plug
LB	Lifting Bale
MPN	Minimum Pressure Nozzle
OC	Oil Cooler
OFc	Oil Filter (Compressor)
OFe	Oil Filter (Engine)
OLG	Oil Level Gauge
R	Radiator
RV	Regulating Valve
S	Starter Motor Engine
SR	Speed Regulator
SV	Safety Valve
TT	Top Tank
TBV	Thermostatic By-pass valve
UV	Unloading Valve
VV	Vacuator Valve

Reference	Name
AFc	Air Filter Compressor
AFe	Air Filter Engine
AFE	Air Filter Element
AR	Air Receiver
AV	Air Outlet Valve
BDV	Blow Down valve
BPV	By-Pass Valve Oil Filter
CE	Compressor Element
CH	Coupling Housing
CP	Control Panel
CV	Check Valve
DP	Drain Plug
E	Engine
EW	Electrical Wiring
F	Cooling Fan
FP	Compressor Oil Filling Plug

Reference	Name
M	Manifold
MPN	Minimum Pressure Nozzle
OC	Oil Cooler
OFc	Oil Filter (Compressor)
OFe	Oil Filter (Engine)
OS	Oil Separator
PS	Pressure Sender
RV	Regulating Valve
S	Solenoid
SC	Safety Cartridge
SL	Scavenge Line
SV	Safety Valve
TS	Temperature Switch
UV	Unloader Valve
Vi	Vacuum Indicator

Air flow

The system comprises:

AF	Air filter
AR/OS	Air receiver/oil separator
CE	Compressor element
UA/UV	Unloader assembly with unloader valve
BDV	Blow-down valve
MPV	Minimum pressure valve
LV	Loading Valve

Air drawn through the airfilter (AF) into the compressor element (CE) is compressed. At the element outlet, compressed air and oil pass into the air receiver/oil separator (AR/OS).

In the air receiver/oil separator (AR/OS), most of the oil is removed from the air/oil mixture: the remaining oil is removed by the separator element. The oil collects in the receiver and on the bottom of the separator element.

The oil collects in the receiver and on the bottom of the separator element.

The air leaves the receiver via the minimum pressure nozzle (MPN) which prevents the receiver pressure from dropping below the minimum working pressure, even when the air outlet valves are open. This ensures adequate oil injection and prevents oil consumption.

A temperature switch (TS) and a working pressure gauge (PG) are comprised in the system.

A blow-down valve (BDV) is fitted in the unloader assembly to automatically depressurize the air receiver (AR) when the compressor is stopped.

Oil system

The system comprises:

AR/OS	Air receiver/oil separator
RV/UA	Regulation Valve/Unloader Valve
OC	Oil cooler
OF	Oil filter

The lower part of the air receiver (AR) serves as oil tank.

Air pressure forces the oil from the air receiver/oil separator (AR/OS) through the oil cooler (OC) and oil filter (OF) to the compressor element (CE).

The compressor element has an oil gallery in the bottom of its casing. The oil for rotor lubrication, cooling and sealing is injected through holes in the gallery.

Lubrication of the bearings is ensured by oil injected into the bearing housings.

The injected oil, mixed with the compressed air, leaves the compressor element and re-enters the air receiver, where it is separated from the air as described in section 2.4. The oil that collects in the bottom of the oil separator element is returned to the system through scavenging line (SL), which is provided with a flow restrictor (FR).

The oil filter by-pass valve opens when the pressure drop over the filter is above normal because of a clogged filter. The oil then by-passes the filter without being filtered. For this reason, the oil filter must be replaced at regular intervals.

Continuous regulating system

The system comprises:

RV	Regulating valve
UA	Unloader Valve
SR	Speed regulator

The compressor is provided with a continuous regulating system. This system is provided with a blow-down valve (BDV) which is integrated in the unloader assembly (UA). The valve is closed during operation by outlet pressure of the compressor element and opens by air receiver pressure when the compressor is stopped.

When the air consumption increases, the air receiver pressure will decrease and vice versa. This receiver pressure variation is sensed by the regulating valve which, by means of control air to the unloader, matches the air output to the air consumption. The air receiver pressure is maintained between the pre-selected working pressure and the corresponding unloading pressure. When starting the compressor, the unloader valve (UV) is kept open by spring force, the engine runs at maximum speed. The compressor element (CE) takes in air and pressure builds up in the receiver. The unloader valve is closed.

The air output is controlled from maximum output (100%) to no output (0%) by:

1. Speed control of the engine between maximum load speed and unloading speed (the output of a screw compressor is proportional to the rotating speed).
2. Air inlet throttling.
3. Blow off valve (BOV).

If the air consumption is equal to or exceeds the maximum air output, the engine speed is held at maximum load speed and the unloading valve is fully open.

If the air consumption is less than the maximum air output, the regulating valve supplies control air to unloader valve (UV) to reduce the air output and holds air receiver pressure between the normal working pressure and the

corresponding unloading pressure of approx. 21.75 psi (1.5 bar) above the normal working pressure.

When the air consumption is resumed, the unloader valve gradually opens the air intake and the speed regulator increases the engine speed.

The construction of the regulating valve is such that any increase (decrease) of the air receiver pressure above the pre-set valve opening pressure results in a proportional increase (decrease) of the control pressure to the unloading valve.

Part of the control air is vented to atmosphere, and any condensate discharged, through the vent holes (VH).

Electric system

CIRCUIT DIAGRAM - 1310 3200 51

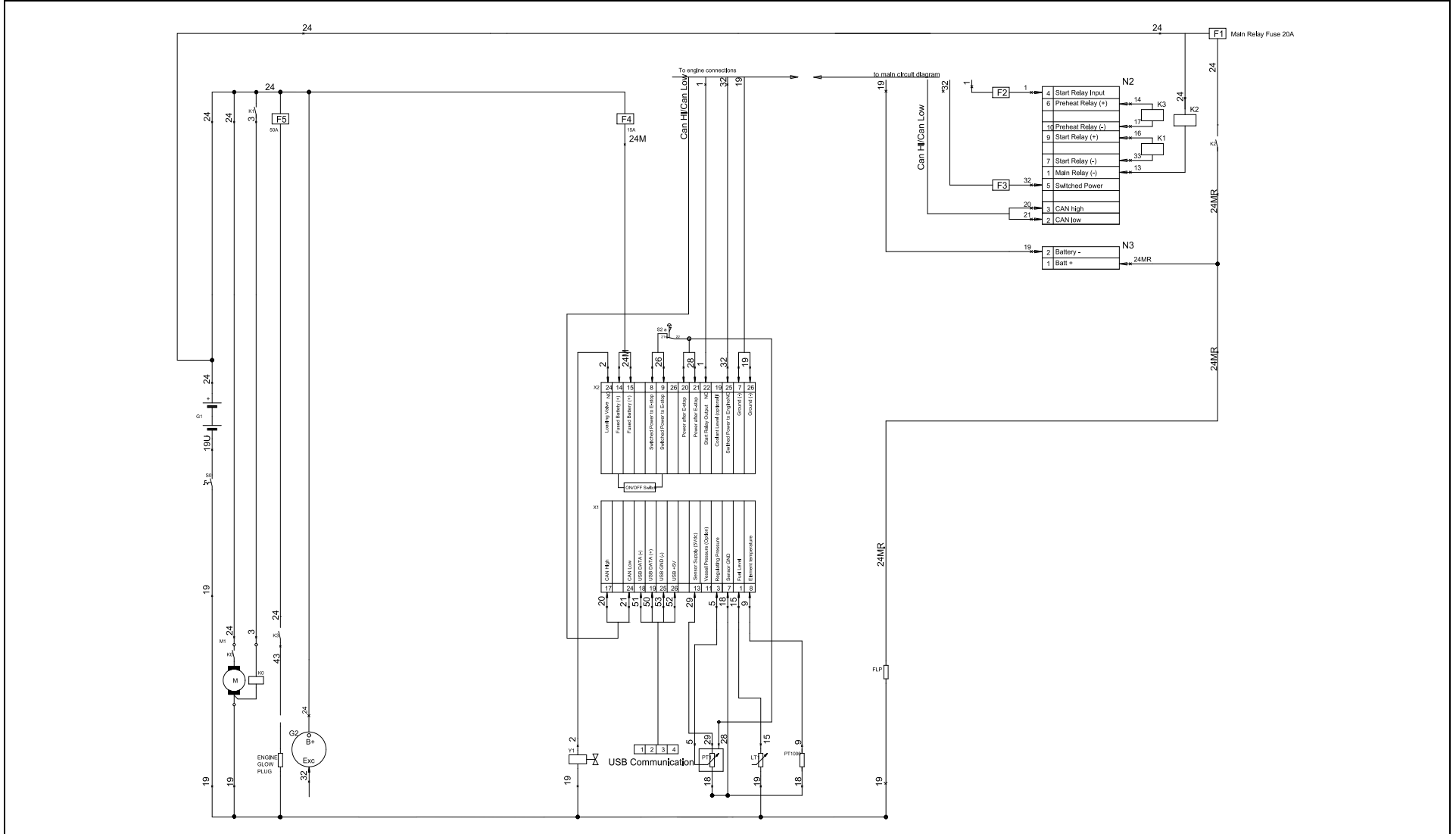

Reference	Name
FLP	Fuel Lift Pump
F1	Main Relay Fuse (20A)
F2	Start Relay Fuse (5A)
F3	Ignition Fuse (5A)
F4	Xc2003 Fuse (15A)
F5	Glow Plug Fuse (50A)
G1	Battery
G2	Alternator
K0	Starter Motor Solenoid
K1	Relay - Starter Motor
K2	Relay - Main
K3	Relay - Preheat
LT1	Level Sensor - Fuel Level
M1	Starter Motor
N1	Control module - Xc2003
N2	Kubota V1C1 Connector
N3	Kubota Main Power Connector
PT1	Pressure Sensor - Regulating Pressure
R3	Grid/Glow plug heater
S2	Emergency Stop
TS1	Temperature Switch
	Compressor Element Temperature
X1	ECU Connector
X2	ECU Connector
Y1	Loading Valve

Operating instructions

Parking, towing and lifting instructions

Safety precautions



The operator is expected to apply all relevant Safety precautions for portable compressor.

Attention



Check and retighten the wheel nuts and drawbar bolts to the specified torque. See section Technical Specifications.

DRAWBAR PREPARATIONS FOR TOWING

Atlas Copco XAS 185 KD7 compressors may be supplied to a customer with a folded drawbar. The drawbar is positioned in its upright position for shipping purposes only. When the compressor is received by the end customer, the drawbar will need to be put into its operating position. To do this:

1. With the weight of the compressor still on the drawbar, pull the pin on the jacking device (prop or nose wheel) and move it into the down position. Be sure to reinsert the pin to keep the jack locked in place.
2. Use the jack to support the compressor in a level position by turning the handle at the top of the jack.
3. Using the appropriate tools, remove the shipping bracket and fold the drawbar into its down position. Discard locknut.

Note: take the necessary precautions as to not pinch the wire harness that runs through the drawbar during the unfolding process. Pull the excess harness out through the front of the drawbar.

4. Reuse the shipping bracket bolt to secure the drawbar by reinserting the bolt through both drawbar halves (item 2, 3). Secure and tighten with the locknut supplied in the shipping bag. Torque the nut and bolt to 130 ft-lbs.

5. Using a jack stand or by blocking, support the end of the drawbar. With the compressor properly supported remove the prop or nose wheel and tighten the pivot nut/bolt. Torque the nut and bolt to 130 ft-lbs.
6. Re-attach the prop to the drawbar in the down position and install keeper pin. Jack the unit up with the prop to remove the blocking.
7. Using bolt, washers, and locknut (items 4,5,6) from shipping bag, insert bolt through hole on top of drawbar using washers and secure with locknut. Torque nut and bolt to 130 ft-lbs.
8. Discard any remaining hardware and the shipping bracket.
9. Retorque the all drawbar attachment bolts to their specified value after 5-10 hours of use.

Note: the pivoting feature of the drawbar is for shipping purposes only. The drawbar is to remain in the down position after its initial setup. **REUSE OF LOCKNUTS IS STRICTLY PROHIBITED BY ATLAS COPCO**

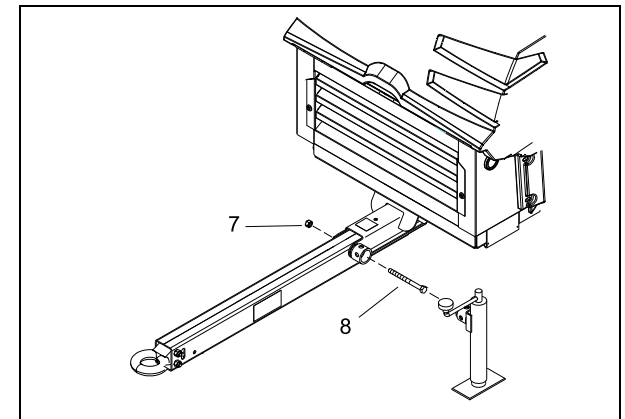
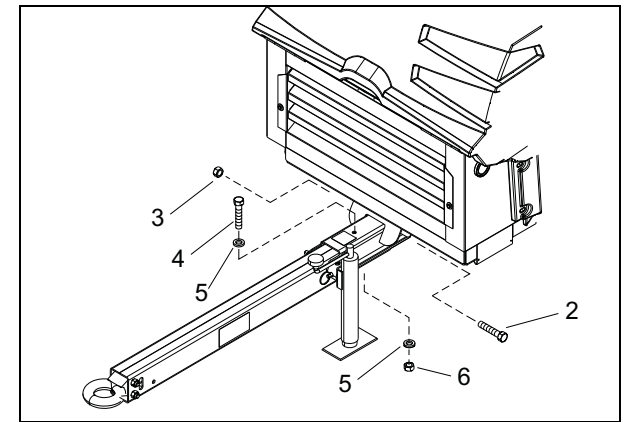
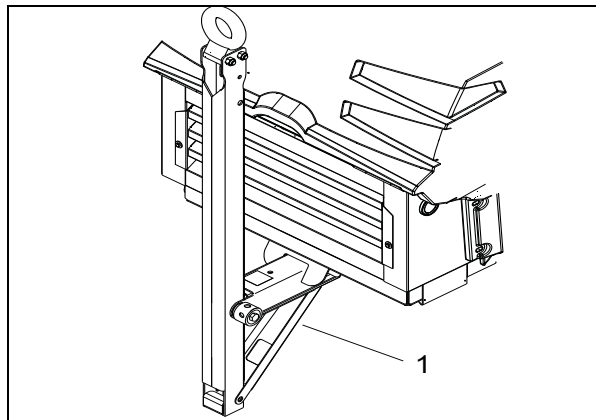

Starting / Stopping

Safety precautions



Do not disconnect power supply to control box in any way when the control box is switched on. This will cause memory loss.

Do not switch off the circuit breaker when the control box is switched on. This will cause memory loss.

Battery switch

If the compressor is equipped with a battery switch:

When the compressor is not in use this switch must always be in the “OFF” position.

It is not allowed to use this switch as an emergency switch or for stopping the compressor. It will cause damage in the control unit when using this switch for stopping.







Always first shut off the control unit and wait until the display is dark before switching the battery switch to position “OFF”.

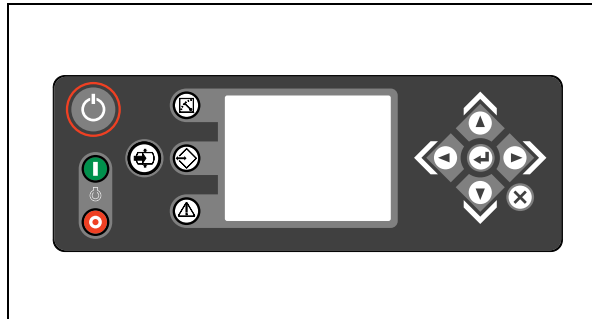



Please be aware that the (optional) preheater unit is still “live” with the battery switch in “OFF” position.

Control panel









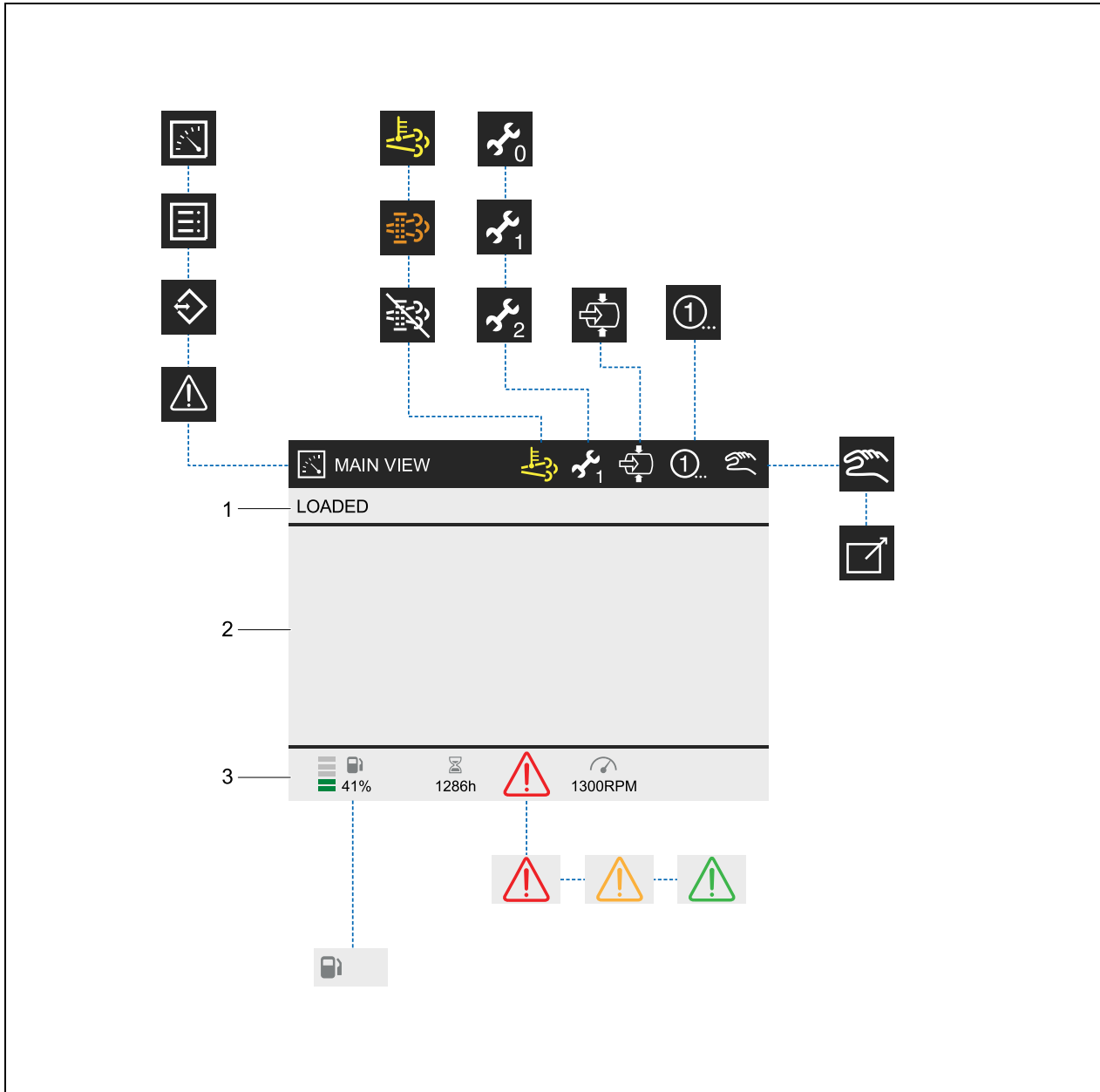



Reference	Name
	START BUTTON: This button will initiate the starting sequences if the controller is in Ready To Start Sequence, or will re-enter the normal running sequence when in Cooldown Sequence.
	STOP BUTTON: This button will initiate the cooldown/stopping sequences if the controller is in normal running sequence.
	LOAD BUTTON: This button will:- initiate the Auto Load function when the controller is in normal running sequence, but not ready to be loaded. - initiate the loading sequences when the controller is ready to be loaded. - initiate the not loaded sequence when the controller is running in Loaded Sequence
	MEASUREMENTS VIEW BUTTON: This button will enter the Measurements View when not already in the Measurements View, or when already in the Measurements View it will enter the Main View.
	SETTINGS VIEW BUTTON: This button will enter the Settings View when not already in the Settings View, or when already in the Settings View it will enter the Main View.
	ALARMS VIEW BUTTON: This button will enter the Alarms View when not already in the Alarms View, or when already in the Alarms View it will enter the Main View.







	NAVIGATION BUTTONS: These buttons are used to navigate through the display menu's.
	ENTER BUTTON: Confirms/stores the selection/change.
	BACK BUTTON: Moves back one level or ignores the change.

OVERVIEW ICONS



Reference	Name
1	Compressor status
2	Vessel pressure indication or info text
3	Compressor info
	Main View Indication
	Measuring View Indication
	Settings View Indication
	Alarm View Indication
	DPF REGENERATION High Exhaust System Temperature. Means that the Diesel Particle Filter is being regenerated.
	DPF REGENERATION NEEDED Means that the Diesel Particle Filter needs to be regenerated. Please force DPF Regeneration.

Reference	Name
	<p>DPF REGENERATION INHIBITED Diesel Particle Filter Regeneration Inhibited. Means that the DPF regeneration is inhibited, even if all criteria to activate a regeneration are met.</p>
	<p>OVERHAUL Initial Overhaul required.</p>
	<p>OVERHAUL Minor Overhaul required.</p>
	<p>OVERHAUL Major Overhaul required.</p>
	<p>AUTO LOAD This icon will be shown if the Auto Load functionality is enabled, or by means of a parameter setting, or by means of pressing the load button before the machine is ready to be loaded.</p>

Reference	Name
	<p>OPERATION MODE Local</p>
	<p>OPERATION MODE Remote</p>
	<p>ALARM Active & not-acknowledged Shutdown Alarm.</p>
	<p>ALARM Active & not-acknowledged Non-Shutdown Alarm.</p>
	<p>ALARM Active & acknowledged Alarm.</p>
	<p>FUEL TANK Running at internal fuel tank.</p>

Possible views

Main View

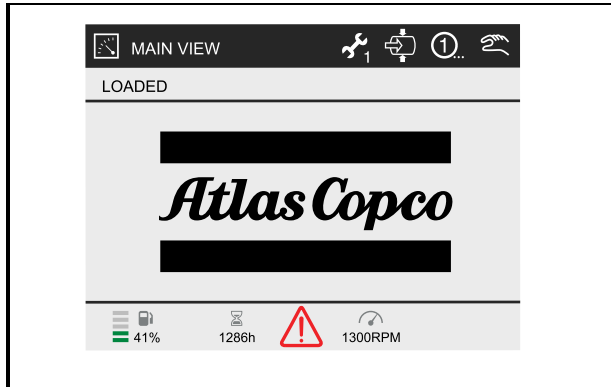

Measuring View

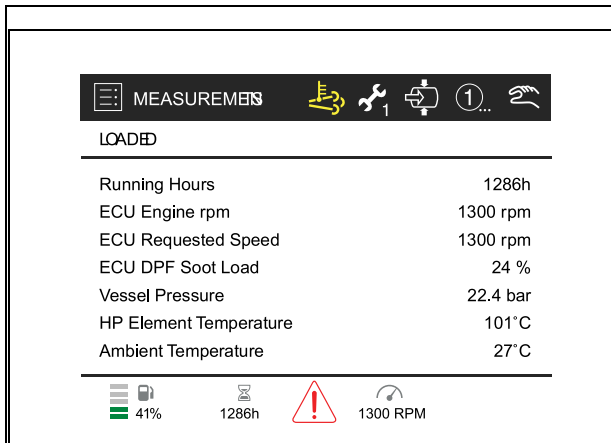

Use the Up and Down navigation buttons to scroll through the full list of measurements.

Setup View

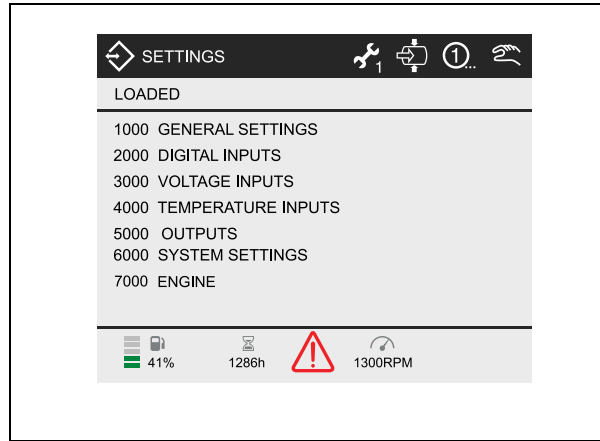

Use the Up and Down navigation buttons to scroll through the full list of settings.

Use the Enter button to enter the selected submenu.

Use the Back button to leave the entered (sub)menu.

Alarm View

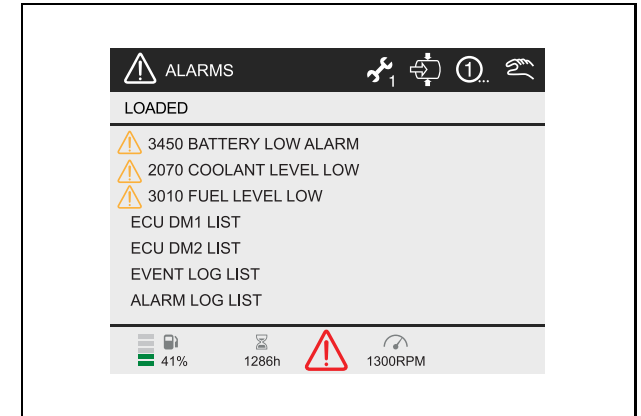

Use the Up and Down navigation buttons to scroll through the full list of alarms.

The DM Lists and the Log Lists can be selected and entered to access the sublist.

STARTING

Switch on the battery switch if so equipped.

Switch the controller on by pressing the power button.

The instrument panel will now perform a selftest; the following display will be shown and the controller is initialized:

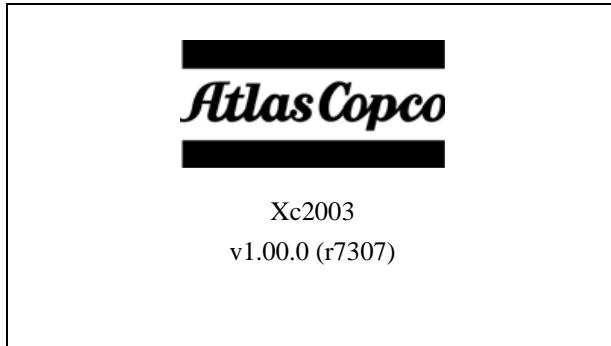

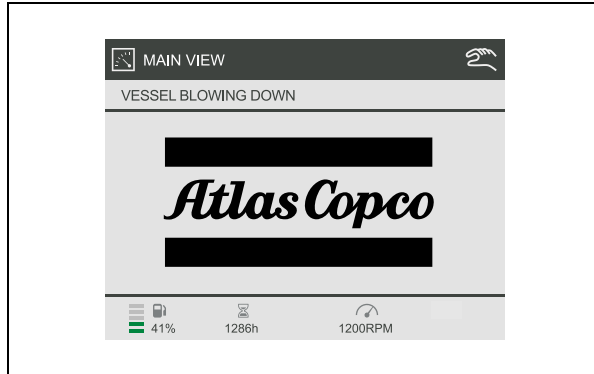

During initializing all buttons/inputs/outputs/alarms are inactive.

This view will be shown for about 2 seconds, after which the display will show the Main View.





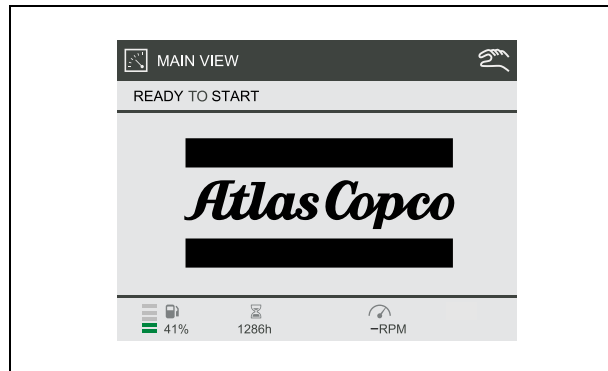

The actual vessel pressure is shown. If the measured vessel pressure is higher than 1.5 bar, the unit will not start. The vessel pressure has to be lowered by opening the blow down valve. After power up, the vessel pressure normally is low enough to proceed with the starting procedure.

Active Buttons	
	Measurement View Button
	Settings View Button
	Alarms View Button

The display now shows



The machine is now ready to be started and is waiting for a start command.

Active Buttons	
	Start Button (to initiate Start command)
	Measurement View Button
	Settings View Button
	Alarms View Button

The display now shows

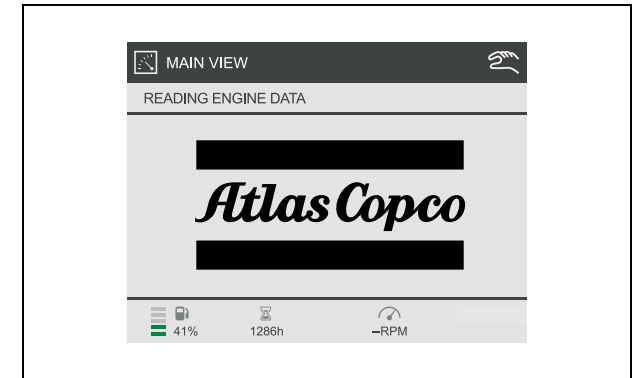

After pressing the START button, the engine electronics (ECU) will be powered up.

As soon as communication between compressor controller and engine controller is established, the machine will preheat according to the parameters of the engine controller.

The display now shows



The engine starts cranking, the display shows

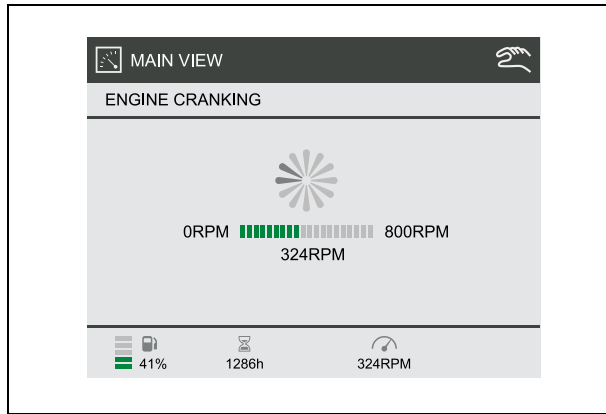







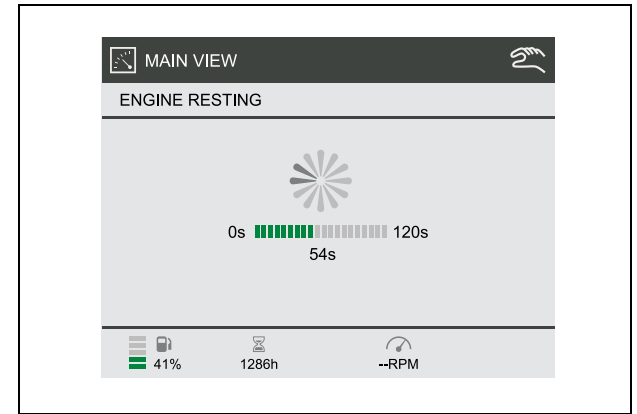

The engine cranks until 800 rpm is reached.

If 800 rpm is not reached within 30 seconds, the starting procedure is cancelled and the engine will rest for some time. (Resting time depends on cranking time).

The display now shows



Active Buttons	
	Stop Button (to cancel Start command)
	Measurement View Button
	Settings View Button
	Alarms View Button

Active Buttons	
	Stop Button (to cancel Start command)
	Measurement View Button
	Settings View Button
	Alarms View Button



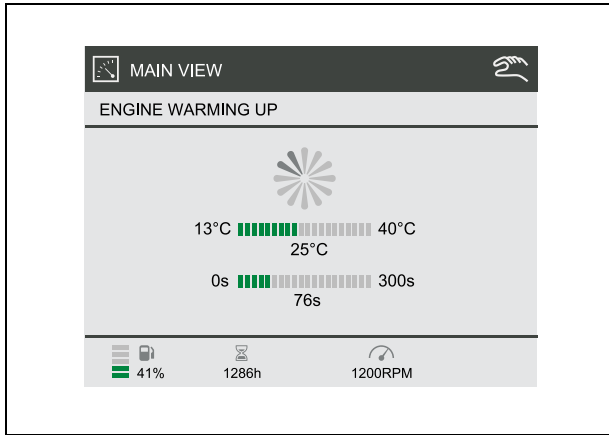

The engine starts running at idle speed. The display shows

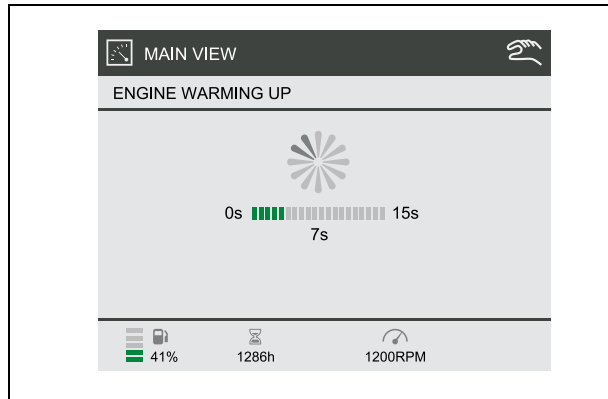

The engine will run at minimum rpm, until the engine's coolant temperature reaches 40 deg C (104 deg F), with a minimum time of 15 seconds and a maximum time of 300 seconds.





The display now shows



Active Buttons	
	Stop Button (to cancel Start command)
	Measurement View Button
	Settings View Button
	Alarms View Button

After warming up the machine is ready to be loaded and is waiting for a load command; the display shows





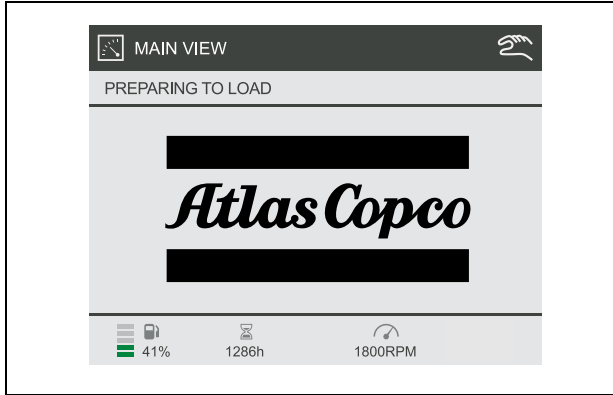

Active Buttons	
	Stop Button (to cancel Start command)
	Load Button (to initiate Automatic Load)
	Measurement View Button
	Settings View Button
	Alarms View Button

The engine will now run at maximum rpm, the display will show





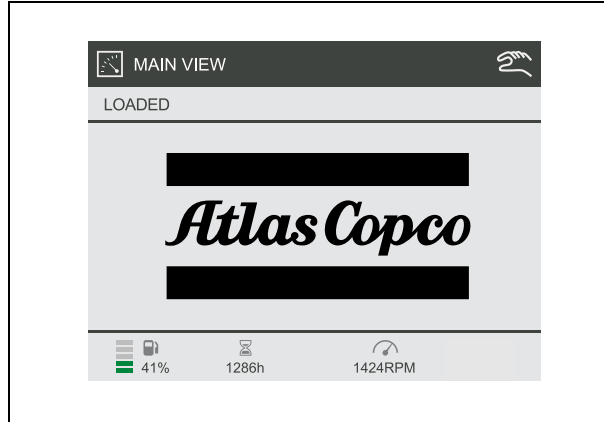

The loading valve will be energized and pressure starts building up.

Active Buttons	
	Stop Button (to cancel Start command)
	Load Button (to cancel Load command)
	Measurement View Button
	Settings View Button
	Alarms View Button

During loading the following display is shown (default display)



The controller controls the speed of the engine in order to meet the requested working pressure, at the most economical fuel usage.

Active Buttons	
	Stop Button (to cancel Start command)
	Load Button (to cancel Load command)
	Measurement View Button
	Settings View Button
	Alarms View Button

During operation



The doors must be closed during operation and may be opened for short periods for inspection and adjustments only.



Be aware not to touch hot or moving parts when the door is open.



When the engine is running, the air outlet valves (ball valves) must always be put in a fully opened or fully closed position.

Regularly carry out following checks:

1. Ensure that the regulating valve (RV) is correctly adjusted, i.e. starts decreasing the engine speed when reaching the preset working pressure in the receiver.
2. Check the air outlet temperature of the compressor element.
3. Check the engine oil pressure, the coolant temperature and display of control box.
4. Avoid the engine running out of fuel. Nevertheless, if this happens, fill the fuel tank and prime the fuel system to speed up starting.

STOPPING

After pressing the STOP button the display will show:

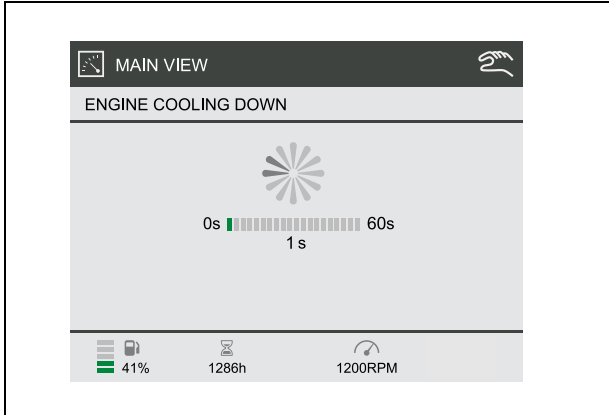

After a Stop command, or in case of a controlled stop alarm, the machine will cool down and run at minimum rpm for 1 minute before it will stop.

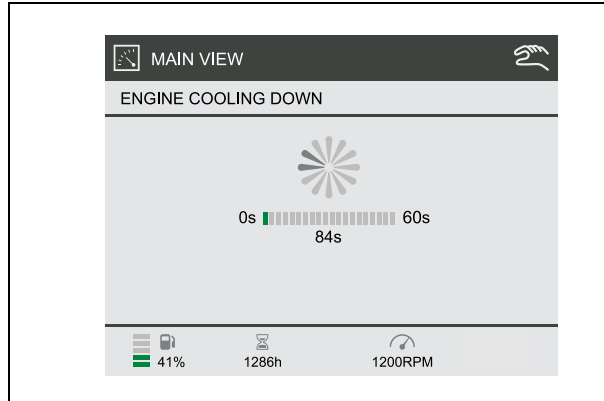

Active Buttons	
	Start Button (to initiate Start command)
	Measurement View Button
	Settings View Button
	Alarms View Button

After cooling down the engine will stop and the display will show

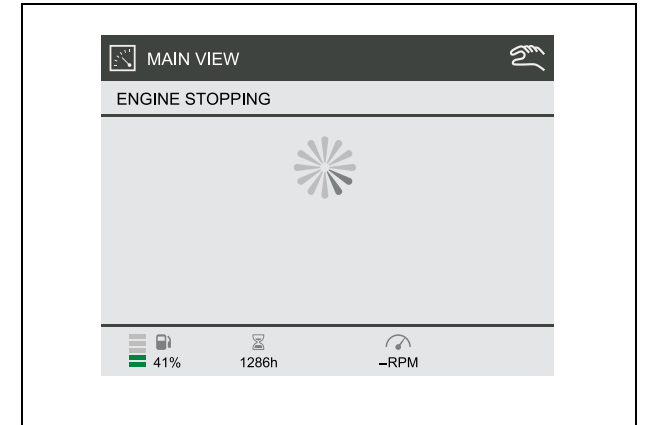





The engine is stopped, and the controller will do a double check to see if the engine is really stopped.

Active Buttons	
	Start Button (to initiate Start command)
	Measurement View Button
	Settings View Button
	Alarms View Button

SHUTDOWN

When the machine is shutdown due to a critical alarm or an emergency stop the display will show



Active Buttons	
	Measurement View Button
	Settings View Button
	Alarms View Button
	Enter Button (to acknowledge the shown alarm)

POWER OFF

Switch the controller off by pressing the Power button.

If the compressor is equipped with a battery switch:

When the compressor is not in use, this switch must always be in the “OFF” position.

It is not allowed to use this switch as an emergency switch or for stopping the compressor.

It can damage the controller or the engine’s Electronic Control Unit when using the battery switch for stopping.

Always first shut off the controller and wait until the display is dark before switching the battery switch to position “OFF”.

DIESEL PARTICULATE FILTER REGENERATION

When the Diesel Particle Filter regeneration process is kept at its default ‘AUTOMATIC’ setting, then the DPF regeneration will be performed automatically when the Soot Load exceeds 60%.

The controller display will indicate an ongoing DPF Regeneration by showing the HEST icon (High Exhaust System Temperature):

	HEST Icon
---	-----------

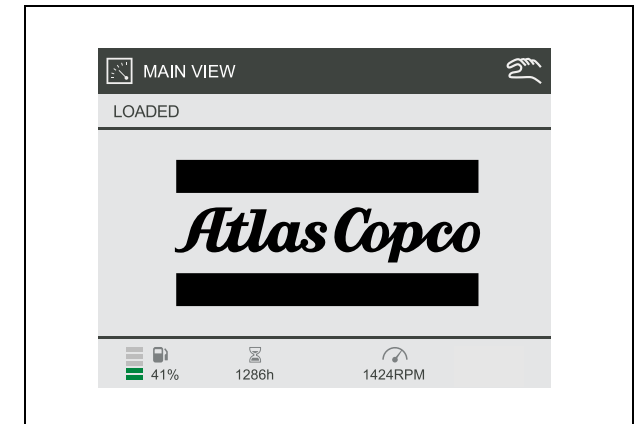

The DPF regeneration process will continue, until the Soot Load has become as low as possible, or until the engine is stopped.

When the DPF regeneration process is stopped, the HEST icon will disappear from the display.

AUTOMATIC DPF REGENERATION (DEFAULT)

In specific cases, when the engine speed is constant at Minimum RPM, it can happen that the DPF regeneration already starts from 30% Soot Load (LSR - Low Speed Regeneration).

This can happen in following situations:

- Warming Up
- Not Loaded
- Loaded (when running in Unload condition - minimum RPM)
- Cooldown

When an LSR is ongoing while the soot load is less than 60%, and the engine speed changes (engine is stopped, machine gets loaded, ...), then the DPF Regeneration process will be stopped.

If the Soot Load is higher than 30% when cooling down should start (then an LSR is expected to be started) the controller will ask:

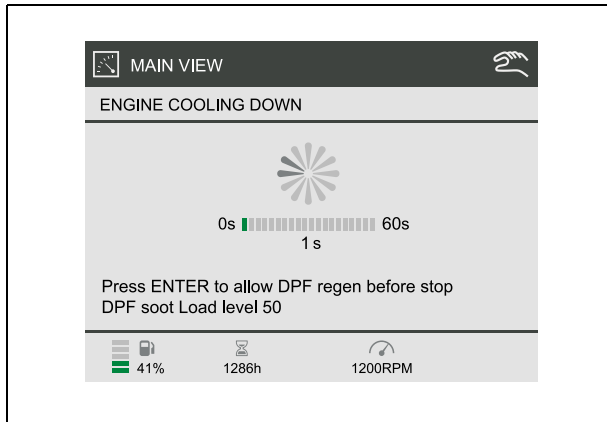

If Enter is pressed within 10 seconds then the controller will allow the DPF regeneration to be completed before the engine is stopped.

 **A full DPF Regeneration can take up to an hour.**

If Enter is not pressed (within 10 seconds), then the engine will be stopped after cooling down.

INHIBIT DPF REGENERATION

When running in an environment where an elevated exhaust temperature is not allowed, it might be necessary to inhibit DPF regeneration. This has to be done at Customer Service Level. Go to General settings 1000. Parameter 1142 ECU DPF Regeneration Enable - Set to "OFF". The controller has now put the DPF Regeneration in a FORCED OFF mode, which is Inhibit DPF Regeneration.

The compressor controller will communicate with the engine controller and the (RED) Inhibit DPF regeneration icon will appear:

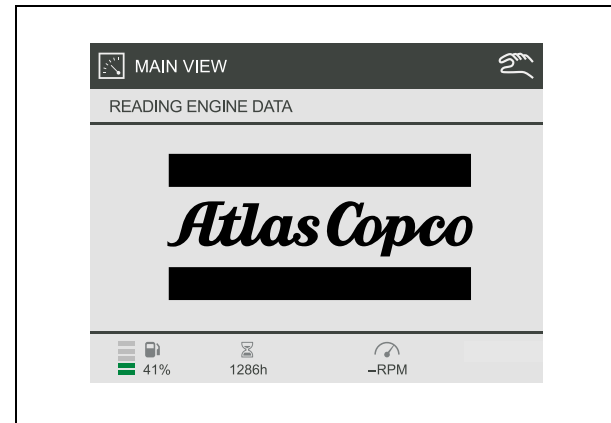
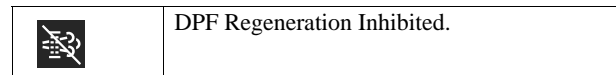

When the controller gets powered down, it will (at next power up) fall back to its default settings, meaning AUTOMATIC DPF regeneration.

INCREASING SOOT LOAD

When the DPF Regeneration is Inhibited, or when the engine does not get sufficient possibility to automatically perform a full DPF Regeneration, the Soot Load will exceed the normal levels.

The controller will show the DPF Regeneration Needed Icon. In case of Inhibited DPF Regeneration, the DPF Regeneration Needed Icon will overwrite the DPF Inhibited Icon.

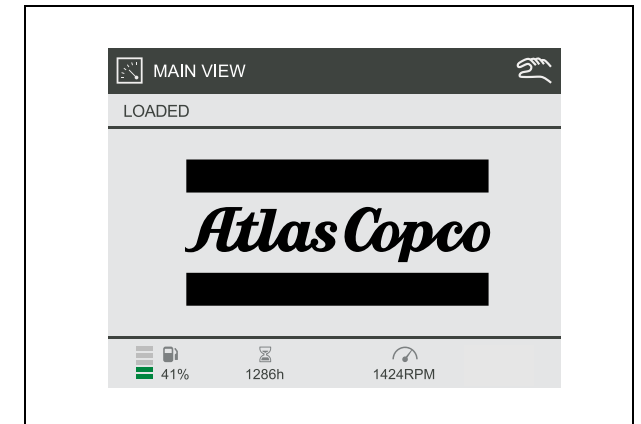
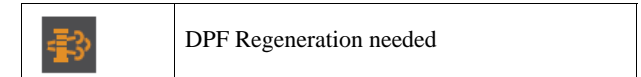

Required Action:

- Force DPF Regeneration, see paragraph FORCE DPF REGENERATION

When DPF Regeneration is started, the DPF Regeneration Needed icon will disappear and the HEST icon will pop-up.

TURNING REGENERATION BACK TO AUTO

Machine is not running:

Power the controller down. At next power up, the DPF Regeneration settings will be back to default, and an Automatic DPF Regeneration will take place at the soonest appropriate moment.

Machine is running:

- Press the Settings View Button
- Enter the '1000 GENERAL SETTINGS' menu
- Scroll one line down and Enter the '1140 ECU DPF REGENERATION' menu
- Scroll down and Enter the 'MODE' parameter
- Scroll down and Enter the 'AUTOMATIC' setting
- Press the Back button 3 times to get back to the Main view
- Also make sure parameter '1142 ECU DPF REGENERATION ENABLE' is set to "ON"

DPF Regeneration setting will now be AUTOMATIC DPF REGENERATION.

Customer Level can now select between AUTO Regeneration & INHIBIT Regeneration, as long as the controller is not powered down (after power down, it will fall back to its default DPF Regeneration settings, and a Service Level is needed to go back to Inhibit DPF Regeneration).

FORCE DPF REGENERATION

Machine is running:

- Press the Settings View Button
- Enter the '1000 GENERAL SETTINGS' menu
- Go to parameter '1130 STATIONARY REGENERATION'
- Scroll to Enable and change to "ON"



Unit will not regenerate if soot level is not high enough.

SERVICE REGENERATION

Machine is running:

- Press the Settings Menu
- Enter the '7000 ENGINE' menu
- Go to parameter '7140 SERVICE REGENERATION'
- Scroll to Enable and change to "ON"



Unit will not regenerate if soot level is not high enough.

SETTINGS

For buttons to be used see "Control Panel"

Acknowledge an Alarm

If an alarm becomes active, for example a Low Fuel Level Warning:



then this alarm can be acknowledged by pressing the ENTER button. If the fuel level is still low, the view will change to:

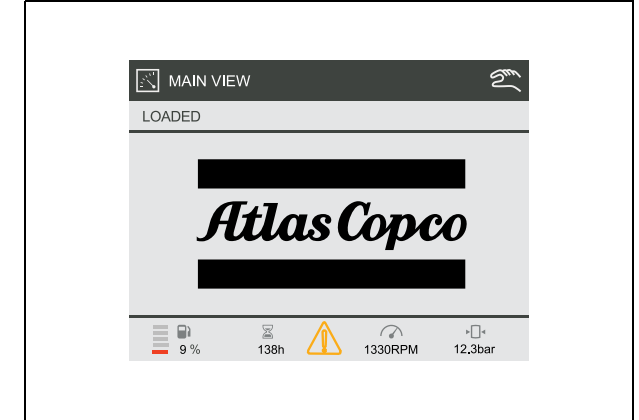

As soon as the fuel level is higher than the warning level, the alarm icon will automatically disappear.

As long as there is an alarm icon in the middle of the bottom part of the view, all active acknowledged /

unacknowledged alarms can be seen by pressing the ALARM VIEW button

Pressing the ALARM VIEW button again, will bring you back to the Main View.

Set Clock

Press the SETTINGS VIEW button

- scroll to '1000 GENERAL SETTINGS'
- press ENTER
- scroll to '1290 DATE/TIME'
- ENTER the Date/Time menu
- scroll to the parameter you want to change
- ENTER this parameter.

To change the 'Month', scroll to the preferred month and press ENTER.

To change any other setting, the highlighted figure is editable.

Scroll up/down and press ENTER to change. Use left/right to shift between editable figures.

Now press BACK until you're back in the Main View (or in the menu you require).

Set Language

Press the SETTINGS VIEW button.

- scroll to '1000 GENERAL SETTINGS'
- press ENTER
- scroll to '1300 LANGUAGES'
- ENTER the LANGUAGES menu,
- ENTER the 'SETTINGS' parameter
- scroll to the preferred language
- press ENTER.

Now press BACK until you're back in the Main View (or in the menu you require).

Set Units

Press the SETTINGS VIEW button,

- scroll to '1000 GENERAL SETTINGS'
- press ENTER

- scroll to the unit you would like to change:
'1340 TEMPERATURE UNITS'
'1350 PRESSURE UNITS'
'1360 FUEL FLOW UNITS'
- ENTER the preferred menu
- ENTER the 'SETTINGS' parameter
- scroll to the preferred setting
- press ENTER.

Now press BACK until you're back in the Main View (or in the menu you require).

Change Display Settings

Press the SETTINGS VIEW button

- scroll to '1000 GENERAL SETTINGS'
- press ENTER
- scroll to '1310 DISPLAY BACKLIGHT'
- ENTER the DISPLAY BACKLIGHT menu
- scroll to the setting you would like to change
- press ENTER.

To change a setting, the highlighted figure is editable. Scroll up/down and press ENTER to change. Use left/right to shift between editable figure.

Now press BACK until you're back in the Main View (or in the menu you require).

Go To Diagnostics

Press the SETTINGS VIEW button

- scroll to '1000 GENERAL SETTINGS'
- press ENTER
- scroll to '1150 DIAGNOSTICS'
- ENTER the Diagnostics menu,
- ENTER the 'ENABLE' parameter
- scroll to 'ON' and press ENTER.

Now the ECU will get power and one can perform ECU diagnostics (read DM1 List, DM2 List, ECU values, perform engine diagnostics, ...).

Now press BACK until you're back in the Main View (or in the menu you require).

To leave Diagnostics, press the STOP button.

- ECU warning 7009 will be active while in diagnostics.

FAULT CODES

There are several parameters that are continuously watched.

When one of these parameters exceeds its specified limit the compressor will react depending the present status of the control box.

Alarmcode	Alarmtext	Failclass	Trigger
1231	FUEL FILL CHECK	Warning	Xc
1503	INITIAL OVERHAUL REQUIRED	Warning	Xc
1522	MINOR OVERHAUL WITHIN ** H	Warning	Xc
1523	MINOR OVERHAUL WITHIN ** D	Warning	Xc
1524	MINOR OVERHAUL REQUIRED	Warning	Xc
1552	MAJOR OVERHAUL WITHIN ** H	Warning	Xc
1553	MAJOR OVERHAUL WITHIN ** D	Warning	Xc
1554	LOAD PREVENTION - FIRE RISK	Inhibit Load	Xc
1558	COMP. OIL CHANGE WITHIN ** H	Warning	Xc
1559	COMP. OIL CHANGE WITHIN ** D	Warning	Xc
2000	EMERGENCY STOP INPUT	Shutdown	Xc
2040	REMOTE EMERGENCY STOP	Shutdown	Xc
2070	COOLANT LEVEL LOW WARNING	Warning	Xc
2080	COOLANT LEVEL LOW SHUTDOWN	Shutdown	Xc
2090	ΔP AIRFILTERS HIGH	Warning	Xc
2100	NO PROJECTFILE DOWNLOADED	Warning	Xc
2752	NAM OILTRONIX BYPASS CIRCUIT	Shutdown After Stop	Xc
2762	NAM OILTRONIX CLOSED CIRCUIT	Shutdown After Stop	Xc
2772	NAM AIRXPRT OPENED CIRCUIT	Shutdown	Xc
2782	NAM AIRXPRT CLOSED CIRCUIT	Shutdown	Xc
3000	FUEL LEVEL LOW WARNING	Warning	Xc
3010	FUEL LEVEL LOW SHUTDOWN	Controlled Stop	Xc
3020	FUEL LEVEL SENSOR CIRCUIT	Warning	Xc
3050	VESSEL PRESSURE HIGH WARNING	Controlled Stop	Xc
3060	VESSEL PRESSURE HIGH SHUTDOWN	Shutdown	Xc
3070	VESSEL PRESSURE SENSOR CIRCUIT	Shutdown	Xc
3120	REGULATING PRESSURE SENSOR CIRCUIT	Shutdown	Xc
3170	AIR DISCHARGE PRESSURE SENSOR CIRCUIT	Warning	Xc
3320	INLET PRESSURE SENSOR CIRCUIT	Shutdown	Xc
3450	BATTERY LOW ALARM	Indication	Xc
3460	BATTERY HIGH ALARM	Warning	Xc
3660	FIRE RISK - CHECK OILSTOPVALVE	Shutdown	Xc
3680	OSV PRESSURE SENSOR CIRCUIT	Controlled Stop	Xc
3720	INTERSTAGE PRESSURE SENSOR CIRCUIT	Warning	Xc
4000	L.P. ELEMENT TEMPERATURE HIGH	Warning	Xc
4010	L.P. ELEMENT TEMP. ALARM 2	Controlled Stop	Xc
4020	L.P. ELEMENT TEMP. ALARM 3	Shutdown	Xc

Alarmcode	Alarmtext	Failclass	Trigger
4040	L.P. ELEMENT TEMP. SENSOR CIRCUIT	Shutdown	Xc
4070	AMBIENT TEMPERATURE SENSOR CIRCUIT	Warning	Xc
4100	AIR DISCHARGE TEMPERATURE ALARM 1	Warning	Xc
4110	AIR DISCHARGE TEMPERATURE ALARM 2	Controlled Stop	Xc
4120	A.D. TEMPERATURE SENSOR CIRCUIT	Warning	Xc
4150	H.P. ELEMENT TEMPERATURE ALARM 1	Warning	Xc
4160	H.P. ELEMENT TEMPERATURE ALARM 2	Controlled Stop	Xc
4170	H.P. ELEMENT TEMPERATURE ALARM 3	Shutdown	Xc
4190	H.P. ELEMENT TEMP. SENSOR CIRCUIT	Shutdown	Xc
4220	AFTERCOOLER AIR TEMP SENSOR CIRCUIT	Warning	Xc
4230	AFTERCOOLER FREEZING DANGER	Indication	Xc
5200	AIR SHUT OFF	Shutdown	Xc
6190	CHARGE MONITORING FAIL	Indication	Xc
6327	START FAILURE	Shutdown	Xc
6329	STARTER SPEED TOO LOW	Shutdown	Xc
6388	VESSEL PRESSURE TOO LOW TO LOAD	Indication	Xc
6426	UNINTENTIONAL RUN	Shutdown	Xc
6427	RUN FAILURE	Shutdown	Xc
6428	STOP FAILURE	Shutdown	Xc
6708	DRAINING 1	Warning	Xc
6709	DRAINING 2	Warning	Xc
6749	OILTRONIX FUNCTIONALITY DISABLED	Warning	Xc
6760	OILTRONIX COUPLING FAILURE	Shutdown After Stop	Xc
6769	OILTRONIX COMPONENT FAILURE	Shutdown	Xc
6981	INLET VALVE POS. FAILURE	Shutdown	Xc
7002	ECU COMMUNICATION	Shutdown	Xc
7007	ECU RED LAMP	Shutdown	ECU
7008	ECU AMBER LAMP	Warning	ECU
7009	ECU PROTECT LAMP	Warning	ECU
7010	ECU ENGINE SPEED TOO LOW	Shutdown	Xc
7020	ECU ENGINE SPEED ALARM 2	Shutdown	Xc
7030	ECU ENGINE COOLANT TEMP. ALARM	Controlled Stop	Xc
7050	ECU ENGINE AIR INLET TEMP. ALARM 1	Controlled Stop	Xc
7100	ECU DPF SOOT LOAD HIGH	Warning	Xc
7110	PLEASE FORCE DPF REGENERATION !	Inhibit Load	Xc
7120	LOAD PREVENTION - HIGH DPF SOOT LOAD	Controlled Stop	Xc
7130	SOOT LOAD TOO HIGH - CALL ATLAS COPCO	Warning	Xc
7222	COMBO COMMUNICATION FAILURE	Warning	Xc
7223	COMBO PA SENSOR WARNING	Warning	Xc
7224	COMBO RHA SENSOR WARNING	Warning	Xc
7225	COMBO TA SENSOR WARNING	Warning	Xc

Details of ECU triggered alarms can be monitored via the ECU DM1 LIST menu

In case of ECU AMBER LAMP or ECU PROTECT LAMP:
Only possible when engine is running or if Diagnostics Mode is active.
Access the ECU DM1 LIST menu via Alarm View.

In case of ECU RED LAMP:
Do NOT acknowledge the ECU RED LAMP alarm.
DM1 alarms are automatically copied into the Alarm View, and can be read there.

For all ECU triggered alarms, the respective SPN code is shown in the ECU DM1 LIST
A full list of supported SPN codes is provided by the engine manufacturer.

For following alarms, the Xc controller also shows full text next to the SPN code:

ECU - FUEL FILTER PRESSURE
ECU - INTERCOOLER TEMPERATURE
ECU - FUEL PRESSURE
ECU - FUEL FILTER PRESSURE
ECU - WATER IN FUEL
ECU - OIL LEVEL
ECU - OIL FILTER PRESSURE
ECU - OIL PRESSURE
ECU - TURBO BOOST PRESSURE
ECU - TURBO OIL PRESSURE
ECU - INTAKE MANIFOLD TEMPERATURE
ECU - AIR INLET PRESSURE
ECU - COOLANT TEMPERATURE
ECU - COOLANT LEVEL
ECU - SUPPLY VOLTAGE

ECU - AMBIENT AIR TEMPERATURE
ECU - AIR INLET TEMPERATURE
ECU - FUEL TEMPERATURE
ECU - OIL TEMPERATURE
ECU - ENGINE SPEED
ECU - INJECTOR 1
ECU - INJECTOR 2
ECU - INJECTOR 3
ECU - INJECTOR 4
ECU - INJECTOR 5
ECU - INJECTOR 6
ECU - INJECTOR 7
ECU - INJECTOR 8
ECU - SOOT LOAD

EMERGENCY STOP

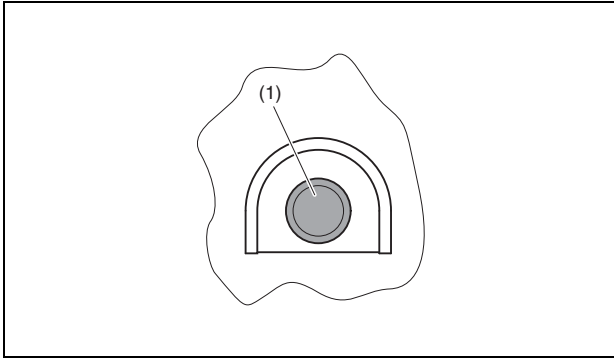

The emergency stop button is only to be used in emergency situations; not for stopping procedures.

When an emergency stop button (1) is pressed, power to all outputs is terminated, by the emergency stop itself (hardware) as well as by the software.

When the emergency stop button (1) is pressed the operator can unlock the emergency stop by turning it counterclockwise.

PARKING INSTRUCTIONS

When parking a compressor, secure prop (1) or nose wheel to support the compressor in a level position. Place the compressor as level as possible; however, it can be operated temporarily in an out-of-level position not exceeding 15°. If the compressor is parked on sloping ground, immobilize the compressor by placing wheel chocks in front of or behind the wheels. Locate the compressor upwind, away from contaminated windstreams and walls. Avoid recirculation of exhaust air from the engine. This causes overheating and engine power decrease.

TOWING INSTRUCTIONS

Before towing the compressor, make sure that the towing equipment of the vehicle matches the towing eye or ball connector

The drawbar should be as level as possible and the compressor and towing eye end in a level position. Secure nose prop (1) in the highest position. Attach safety chains/cables in a crisscross manner to the tow vehicle. This will help prevent the towbar from contacting ground in event of a breakaway. Connect road lights when applicable.

LIFTING INSTRUCTIONS

When lifting the compressor, the hoist has to be placed in such a way that the compressor, which must be placed level, will be lifted vertically. Use the lifting bale provided to lift the unit



Lifting acceleration and retardation must be kept within safe limits (max. 2g).

Helicopter lifting is not allowed.

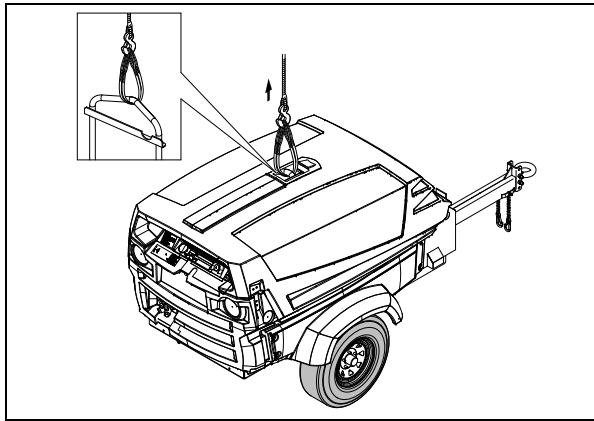

Before Starting



If the compressor is to be connected to a common compressed air system, fit an appropriate check valve between compressor outlet and air system. Observe the right mounting position/direction!

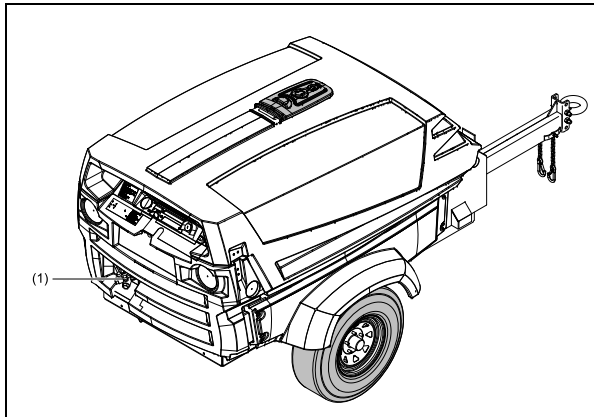

1. Before initial start-up, prepare battery for operation if not already done.
2. With the compressor standing level, check the level of the engine oil. Add oil, if necessary, to the upper mark

on dipstick. Consult the Engine Operation Manual for the type and viscosity grade of the engine oil.

3. Check the level of the compressor oil. The pointer of oil level gauge (OLG) should register in the green range. Add oil if necessary.
4. Check that the fuel tank contains sufficient fuel. Top up, if necessary. Consult the Engine Operation Manual for the type of fuel.
5. Check coolant level in overflow bottle. Top off coolant if necessary. Consult engine's operation manual for water/coolant specifications.
6. Drain any water and sediment from the fuel filter until clean fuel flows from the drain cock.
7. Press vacuator valve (VV) of the air filter to remove dust.
8. Check the air filter service indicator (VI). If the red part shows completely, service or replace the filter element. Reset the indicator.
9. Open an air outlet valve (AV) to allow air flow to the atmosphere.

Maintenance

Use of Service Paks

Service Paks include all genuine parts needed for normal maintenance of both compressor and engine. Service Paks minimize downtime and keep your maintenance budget low. You may order Service Paks from your local Atlas Copco dealer.

Preventive Maintenance Schedule For The Compressor

The schedule contains a summary of the maintenance instructions.

MAINTENANCE SCHEDULE	Daily	Initial 50hours + Every 250/750 hours 1310 9230 03	Every 500 hours 1310 9230 04	Every 1000 hours 1310 9230 05	Note
Check engine oil level	Check				
Check of fuel level	Check				
Check of coolant level	Check				
Check of fan belt	Check		Change	Change	
Change of engine oil		Change	Change	Change	See change interval
Replacement of oil filter cartridge		Replace	Replace w/ oil change	Replace w/ oil change	
*1- Replacement of fuel filter cartridge			Replace	Replace	
Cleaning of water separator			Check		
*2- Cleaning of fuel tank interior			Check		
*2- Cleaning of water jacket and radiator interior			Check		
*2- Replacement of fan belt			Check		
*2- Check of valve clearance				Check	

- When the battery is used for less than 100 hours in a year, check its electrolyte yearly. (for refillable battery's only)
- *1: When biodiesel fuel is used, change the fuel filter cartridge, fuel hose and clamp bands with new ones at intervals half of the usual ones.
- *2: Consult your local KUBOTA dealer for this service.
- The items in the engine manual marked *3 are registered as emission related critical parts by KUBOTA in the U.S. EPA nonroad emission regulation. As the engine owner, you are responsible for the performance of the required maintenance on the engine according to the above instruction. Please see the warranty statement in detail.
- The items listed above are not necessary to keep the emission-related warranty valid.

Read the respective section before taking maintenance measures.

When servicing, replace all disengaged packings, e.g. gaskets, O-rings, washers.

For engine maintenance refer to Engine Operation Manual.

The maintenance schedule has to be seen as a guideline for units operating in a duty environment typical to compressor applications. Maintenance schedule can be adapted depending on application environment and quality of maintenance

- Failure to perform the maintenance will cause problems that will significantly degrade the engine performance.



When changing or inspecting, be sure to level and stop the engine.



Changing interval of engine oil:

Models	Interval
V2403	Every 400 hours

API service classification: above CJ-4 grade

Ambient temperature: below 35 °C (95 °F)

Technical Specifications

Reference conditions

Designation		XAS 185 KD7
Absolute inlet pressure	bar(e)	1
	psi	14.7
Relative air humidity	%	0
Air inlet temperature	°C	20
	°F	68
Normal effective working pressure	bar(e)	7
	psi	100

The inlet conditions are specified at the air inlet grating outside the canopy.

Limitations

Designation		XAS 185 KD7
Minimum effective receiver pressure	bar(e)	4
	psi	58
Maximum effective receiver pressure, compressor unloaded	bar(e)	8.4-8.7
	psi	120-125
Maximum ambient temperature at sea level	°C	52
	°F	125
Minimum starting temperature	°C	-10°C tested @ 12°C
	°F	+14°F
Minimum starting temperature, with coldstart equipment	°C	NA
	°F	NA
Altitude capability	see curves	

XAS 185 KD7 T4F CFM & Engine Speed vs. Altitude at 100 PSI

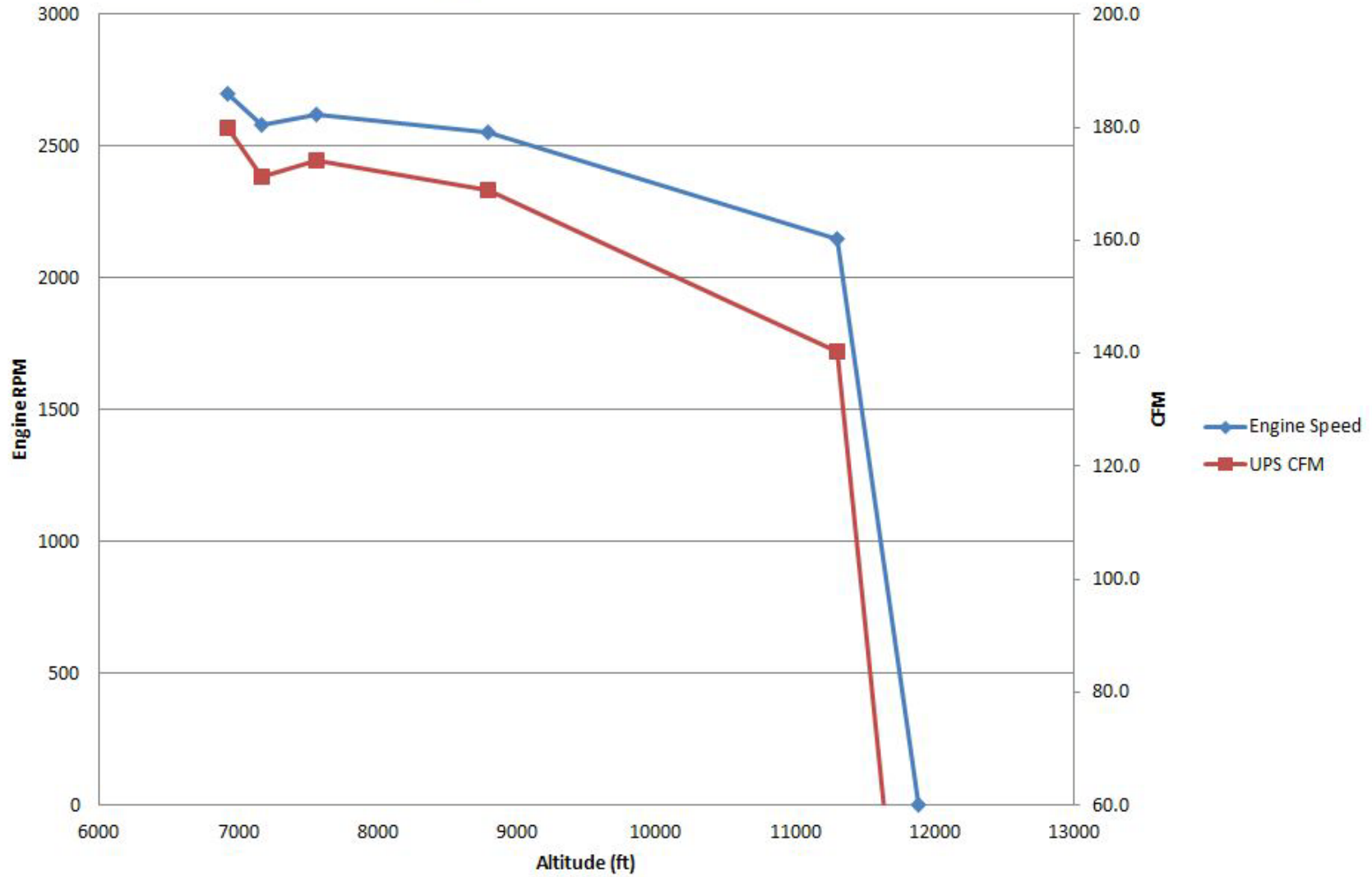

Performance data¹⁾

Designation		XAS 185 KD7
Engine shaft speed, normal and maximum	rpm	2700
Engine shaft speed, compressor unloaded	rpm	1600
Free air delivery ²⁾	l/s	83.53
	cfm	177
Fuel consumption -at full load	gal/hr	2.33
-at unload	gal/hr	0.94
Specific fuel consumption	gal/ft ³	0.00022
Typical oil content of compressed air	mg/m ³	<5
	oz/1000 cu.ft	< 0.005
Engine oil consumption (maximum)	g/hr	NA
	oz/h	NA
Compressed air temperature at outlet valves	°C	93.3
	°F	200
Noise level ⁶⁾	dB(A)	<76

Design Data

COMPRESSOR

Designation	All units
Number of compression stages	1

ENGINE

Designation		XAS 185 KD7
Make		Kubota
Type		V2403
Coolant		Ethylene glycol mix w/SCA package
Number of cylinders		4
Bore	in	3.43
	mm	87.12
Stroke	in	4.03
	mm	102.36
Swept volume	cu.in	148.53
	l	2.43
Output at normal shaft speed ⁵⁾	hp	49
	kW	36.53

Designation		XAS 185 KD7
- Load factor	%	80
Capacity of oil sump	qts	10
	gal	2.5
-Refill (max.) ⁴⁾	qts	11
	gal	2.75
Capacity of cooling system	qts	10
	gal	2.5

UNIT

Designation		All units
Capacity of compressor oil system	qts	12.2
	gal	3.05
Net capacity of air receiver	US gal	4.5
	l	17.03
Capacity of fuel tanks	US gal	20.1
	l	76.08
Air volume at inlet grating (approx.) ³⁾	cfm	6340
	m ³ /s	2.99

- 1) At reference conditions, if applicable, and at normal shaft speed unless otherwise stated.
- 2) Free Air Delivery (volume flow rate) is measured according to ISO 1217 ed.3 1996 annex D

Tolerance:

- +/- 5% 25 l/s (53 cfm) < FAD < 250 l/s (530 cfm)
- +/- 4% 250 l/s (530 cfm) < FAD

The international standard ISO 1217 corresponds to following national standards:

- American ANSI PTC9
- British BSI 1571 part 1
- German DIN 1645 Part 1
- Swedish SS-ISO 1217

3) Air required for engine and compressor cooling, combustion and for compression.

4) with filter change

5) Gross power guaranteed within +/- 5% at SAE J1668 and ISO 3046 conditions:

- 77°F air inlet temperature

- 29.31 in. Hg barometer

- 104°F fuel inlet temperature

- 0.853 fuel specific gravity @ 60°F

6) Measured in accordance with ISO 2151 under free field conditions at 7m distance

1. More frequently when operating in a dusty environment.
2. Replace the element when the pressure drop exceeds 11.5 psi.
3. Refer to the Kubota instruction manual



*** Keep the bolts of the housing, the lifting eye, the towbar and the axle securely tightened. Refer to Compressor/Engine Specifications for the torque values.**

Lubrication oils

It is strongly recommended to use Atlas Copco branded lubrication oils for compressor.

Compressor oil

PAROIL - M	
	Order number
1 gallon pail:	1615 5947 00
5.2 gallon pail:	1615 5948 00
55 gallon drum:	1615 5949 00

PAROIL - S	
	Order number
1 gallon pail:	1630 0160 00
5.2 gallon pail:	1630 0161 00
55 gallon drum:	1630 0162 00
264 gallon container:	1630 0163 00

Engine oil

PAROIL - EXTRA 5W40	
	Order number
1.3 gallon (5 Liter) Container:	1630 0135 01
5.2 gallon (20 Liter) Pail:	1630 0136 01
55 gallon (209 Liter) Drum:	1626 0102 00

PAROIL - E MISSION GREEN 15W40	
	Order number
1.3 gallon (5 Liter) Container:	1630 0471 00
5.2 gallon (20 Liter) Pail:	1630 0472 00
55 gallon (209 Liter) Drum:	1630 0473 00

Engine coolant

PARCOOL - EG	
	Order number
1.3 gallon container:	1604 5308 00
5.3 gallon pail:	1604 5307 01
55 gallon drum:	1604 5306 00
1 gallon pail:	1604 8159 00

Temperature Range	Type of Oil	
	Compressor	Engine
Between -13°F and 122°F ⁽¹⁾	PAROIL S	See Engine Operation Manual
Between 18°F and 104°F	PAROIL M	15W-40

(1) Additional equipment is needed to run the compressor below 18°F. Please contact Atlas Copco for more information about Cold Weather Packages



Operation of compressor in ambient temperatures lower than 18°F (-8°C) without the correct type of oil will void your warranty and may result in element failure and/or fire.

OIL LEVEL CHECK



Never mix oils of different brands or types

CHECK ENGINE OIL LEVEL

Consult also the Engine Operation Manual for the oil specifications, viscosity recommendations and oil change intervals. See schedule.

Check engine oil level according to the instructions in the Engine Operation Manual and top up with oil if necessary.

CHECK COMPRESSOR OIL LEVEL

With the unit standing level, engine stopped, check the level of the compressor oil. The pointer of the oil level gauge (OLG) must register in the upper extremity of the green range. Add oil via the oil fill plug (FP) if necessary.



Before removing oil filler plug, ensure that the pressure is released by opening an air outlet valve.

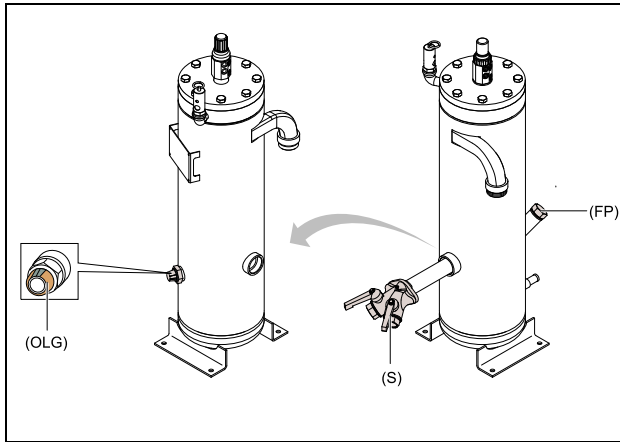

ENGINE OIL AND OIL FILTER CHANGE

Consult also the Engine Operators Manual for oil and oil filter

- (1) change intervals.
- (2) oil types.

COMPRESSOR OIL AND OIL FILTER CHANGE

The quality and the temperature of the oil determine the oil change interval.

The prescribed interval is based on an oil temperature of up to 100°C (212°F) and normal operating conditions.

When operating in high ambient temperatures, in very dusty or high humidity conditions, it is recommended to change the oil more frequently.



In this case, contact Atlas Copco.

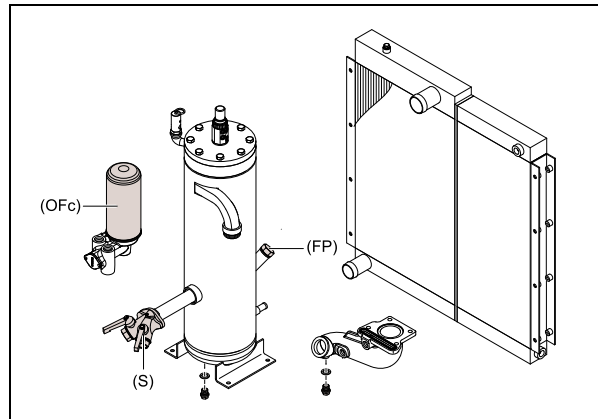

1. Run the compressor until warm. Close the outlet valve(s) and stop the compressor. Wait until the pressure is released through the automatic blow-down valve. Unscrew the oil filler plug (FP) one turn. This uncovers a vent hole, which permits any pressure in the system to escape.
2. Drain the oil by removing all drain plugs. Drain plugs are located at the oil tank, discharge manifold, and oil injection manifold vessel. Catch the oil in a

drain pan. Screw out the filler plug to speed up draining. Tighten the plugs after draining.

3. Remove the oil filter (OFc), e.g. by means of a special tool. Catch the oil in a drain pan.
4. Clean the filter seat on the manifold, taking care that no dirt drops into the system. Oil the gasket of the new filter element. Screw it into place until the gasket contacts its seat, then tighten one half turn only.
5. Fill the air receiver until the pointer of the oil level gauge (OLG) registers in the upper extremity of the green range. Take care that no dirt drops into the system. Reinstall and tighten the filler plug.
6. Run the unit at no load for a few minutes to circulate the oil and to evacuate the air trapped in the oil system.
7. Stop the compressor. Let the oil settle for a few minutes. Check that the pressure is released by opening an air outlet valve (AV). Screw out filler plug (FP) and add oil until the pointer of the oil level gauge (OLG) again registers in the upper extremity of the green range. Reinstall and tighten the filler plug.



Never add more oil. Overfilling results in oil consumption.

Cleaning Coolers

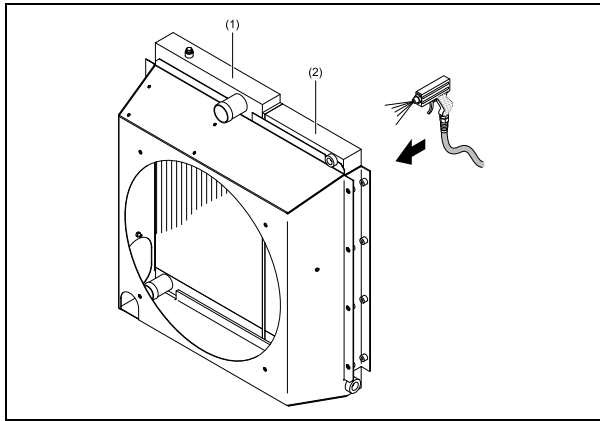

Keep the coolers clean to maintain the cooling efficiency. Front cooler baffle is removable for access by unscrewing 4 bolts.



Remove any dirt from the coolers with a fiber brush. Never use a wire brush or metal objects.

When cleaning by air jet, blow air through the cooler in reverse direction of normal flow.

If the dirt is oily, wash the coolers with degreaser or a cleansing agent.



Protect the electrical and controlling equipment, air filters etc. against penetration of moisture

A spray gun should preferably be used to apply the solvent to the fins. Rinse the blocks by means of a water jet max. 100 psi at 2 inch distance after a soaking-in period. Steam cleaning may also be applied.



To avoid damaging the coolers, angle between waterjet and coolers should be approx. 90°.



Never leave spilled liquids such as fuel, oil, water and cleansing agents in or around the compressor.

Battery Care



Before handling batteries, read the relevant safety precautions and act accordingly.

An ASB (Service Bulletin) dealing elaborately with batteries and due care is available on request.

If the battery is still dry, it must be activated as described in point 4.7.1.

The battery must be in operation within 2 months from being activated; if not, it needs to be recharged first.

ELECTROLYTE



Read the safety instructions carefully

Electrolyte in batteries is a sulphuric acid solution in distilled water.

The solution must be made up before being introduced into the battery.

RECHARGING A BATTERY

Before and after charging a battery, always check the electrolyte level in each cell; if required, top up with distilled water only. When charging batteries, each cell must be open, i.e. plugs and/or cover removed.



Use a commercial automatic battery charger according to manufacturers instructions.

Apply with preference the slow charging method and adjust the charge current according to the following rule of thumb: battery capacity in Ah (amp hours) divided by 20 gives safe charging current in Amps.

BATTERY MAINTENANCE

Keep the battery clean and dry

- Keep the electrolyte level at 10 to 15 mm above the plates or at the indicated level; top up with distilled water only.
- Keep the terminals and clamps tight, clean, and lightly covered petroleum jelly.

Storage

Run the compressor regularly, e.g. twice a week, until warm.

Load and unload the compressor a few times to operate the unloading and regulating components. Close the air outlet valves after stopping.



If the compressor is going to be stored without running from time to time, protective measures must be taken as described In a separate Service Bulletin (ASB), which may be obtained on request. Consult Atlas Copco.

Service Kits

A service kit is a collection of parts to fit a specific repair or rebuilding task.

It guarantees that all necessary parts are replaced at the same time which improves the uptime of the unit.

To purchase service paks contact your local Atlas Copco representative.

Hours Pak	Order number
50/250/750 hrs	1310 9230 03
500 hrs	1310 9230 04
1000 hrs	1310 9230 05

The working pressure is determined by the tension of the spring in the regulating valve (RV). This tension can be increased to raise the pressure and decreased to lower it by turning the adjusting wheel clockwise and counter-clockwise respectively.

To adjust the normal working pressure, proceed as follows:

1. Start and warm up the engine.
2. With the outlet valves (AV) closed, loosen the regulating valve's locknut and adjust the regulating valve (RV) until you reach the desired pressure of 123 psig/8.5 bar(e).
3. Open an outlet valve just enough to let the engine run at maximum speed. The working pressure must be 102 psig/ 7 bar(e). Adjust if necessary with regulating valve (RV).
4. Close the outlet valves, check that the pressure is between 120-126 psig/ 8.3-8.7 bar(e). Lock the regulating valve by fixing the locknut.

Air Filter Engine/Compressor

MAIN PARTS

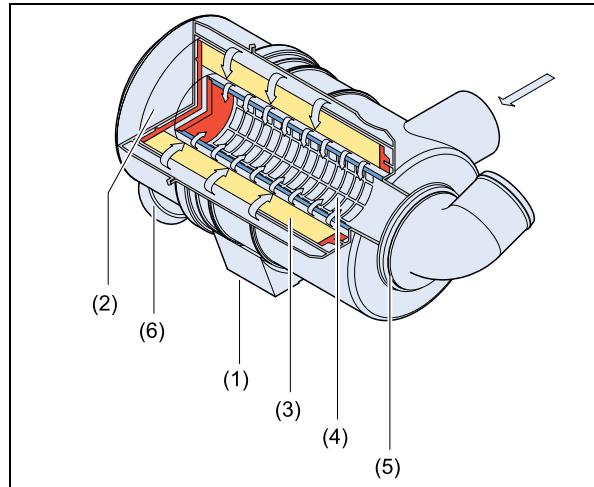

- | | |
|---|-----------------------------|
| 1 | Snap clips |
| 2 | Dust trap |
| 3 | Filter element |
| 4 | Safety cartridge (Optional) |
| 5 | Filter housing |
| 6 | Vacuator valve |

Recommendations



The Atlas Copco air filters are specially designed for the application. The use of non-genuine air filters may lead to severe damage of engine and/or compressor element.

Never run the compressor without air filter element.

New elements must also be inspected for tears or punctures before installation.

Discard the element (3) when damaged.

In heavy duty applications it is recommended to install a safety cartridge.

A dirty safety cartridge (4) is an indication of a malfunctioning air filter element. Replace the element and the safety cartridge in this case.

Replace the safety cartridge together with the filter element. The safety cartridge cannot be cleaned.

CLEANING THE DUST TRAP

To remove dust from the dust trap pinch the vacuator valve (6) several times.

REPLACING THE AIR FILTER ELEMENT

1. Release the snap clips (1) and remove the dust trap (2). Clean the trap.
2. Remove the element (3) from the housing (5). If the element is to be serviced for immediate re-use, reinstall the dust trap to protect the air intake system while cleaning the element.
3. Reassemble in reverse order of dismantling.
4. Inspect and tighten all air intake connections.
5. Reset the vacuum indicator by pushing the reset button.

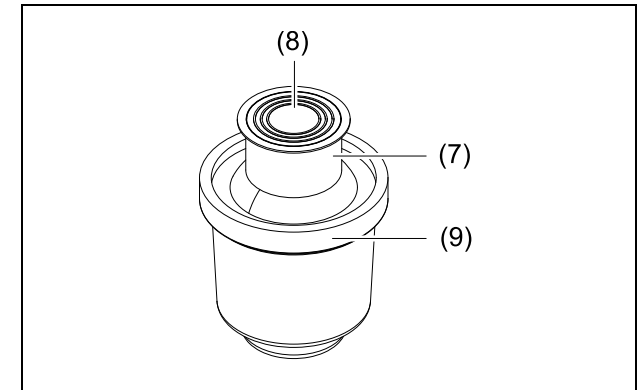

- | | |
|---|------------------------------------|
| 7 | Air filter contamination indicator |
| 8 | Reset button |
| 9 | Red indicator |

Air Receiver

The air receiver is tested according to official standards. Regularly have inspections carried out in conformity with local regulations.

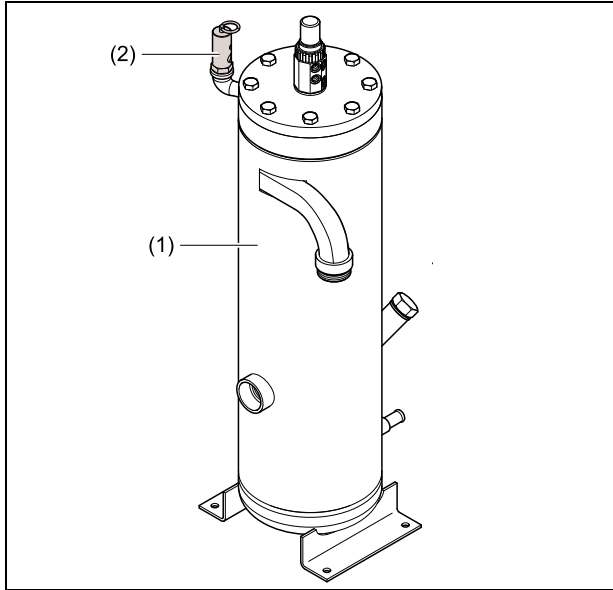

Safety Valve



All adjustments or repairs are to be done by an authorized representative of the valve supplier.

Following checks must be carried out:

- a check of the opening of the lifting gear, twice a year. This can be done by lifting the ring or lever.
- a check of the set pressure once a year according to the local regulations. This check cannot be done on the machine and must be carried out on a proper test bench.

Fuel System

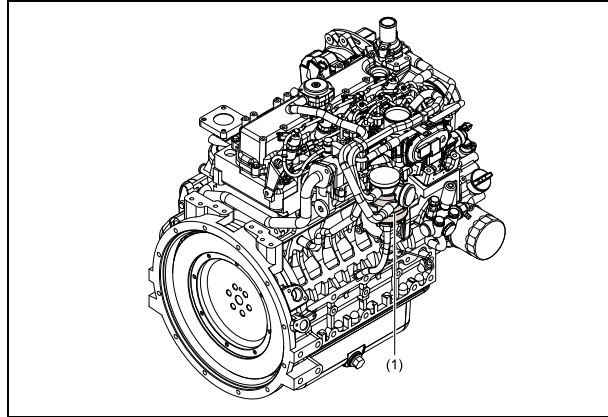

Replacing the filter element:

1. Unscrew the final filter element from the adapter head.
2. Clean the adapter head sealing surface. Lightly oil the gasket of the new element and screw the latter onto the header until the gasket is properly seated, then tighten with both hands.
3. Do not fill with fuel before assembling new filter. Filling the fuel filter introduces dirty (unfiltered) fuel to the injectors.
4. After replacing the final filter's element, prime fuel system with manual prime bulb located below the fuel filter's housing.
5. Check for fuel leaks once the engine has been restarted.

Problem Solving

Problem Solving Chart

Use the chart on the following pages to help solve mechanical problems.

It is assumed that the engine is in good condition, that there is adequate fuel flow to the filter and injection equipment, and compressor/engine maintained with the recommended oil.



An electrical fault must be traced by an electrician.

Make sure that the wires are not damaged and that they are clamped tight to their terminals.

Alternator Precautions

1. Never reverse the polarity of the battery or the alternator.
2. Never break any alternator or battery connections while the engine is running.

3. When recharging the battery, disconnect it from the alternator. Before using booster cables to start the engine, be sure of the polarity and connect the batteries positive to positive, negative to negative.
4. Never operate the engine without the main or voltage sensing cables connected in the circuit.

Problem: Compressor capacity or pressure below normal.

Possible faults	Corrective actions
Air consumption exceeds capacity of compressor.	Check equipment connected.
Choked air filter elements (AF).	Remove and inspect elements. Clean or replace, if necessary.
Regulating valve (RV) defective.	Have regulating valve removed and inspected by an Atlas copco Service representative.
Blow down valve stuck in open position.	Check and correct as necessary.
Loading valve (LV) leaking past O-ring.	With compressor running at max. load speed, disconnect hose leading to unloader. If air leaks from the hose, remove and inspect loading valve. Replace damaged or worn O-rings.
Oil separator element clogged.	Have element removed and inspected by an Atlas copco Service representative.
Air intake throttle valve remains partially closed.	Check unloader and identify reason for open valve; if possible: solve; else: contact Atlas copco.
Safety valve (SV) leaking.	Remove and inspect. Replace if not airtight after reinstallation.
Blow-off valve leaking.	Remove and inspect. Replace if necessary.

Problem: Pressure in air receiver rises above maximum and causes safety valve to blow.

Possible faults	Corrective actions
Regulating valve (RV) opens too late or its ball valve spring is broken.	Have regulating valve removed and inspected by an Atlas copco Service representative.
Air leaks in regulating system.	Check hoses and their fittings. Stop leaks; replace leaking hoses.
Air intake throttle valve does not close for some reason.	Check unloader and identify reason for open valve; if possible: solve; else: contact Atlas copco.
Minimum pressure valve malfunctioning.	Remove and inspect valve.
Blow-off valve malfunctioning.	Remove and inspect valve.

Problem: After working some time, the unit stops through a shutdown switch.

Possible faults	Corrective actions
Engine oil pressure too low.	Refer to the engine instruction manual.
Compressor or engine overheating.	See corrective actions "Compressor overheating".
Fuel tank contains insufficient fuel.	Fill fuel tank.
Low coolant level.	Top up cooling system.

Problem: Air and oil mist expelles from air filters immediately after stopping.

Possible faults	Corrective actions
Check valve at element outlet.	Remove and inspect. Replace if necessary. Replace air filter elements and safety cartridges. Check the oil level and add oil if necessary. Run the compressor for a few minutes, stop and recheck oil level.

Problem: Compressor overheating.

Possible faults	Corrective actions
Insufficient compressor cooling.	Locate compressor away from walls; when banked with other compressors, leave space between them.
Oil cooler clogged externally.	Clean oil cooler. Refer to section Cleaning Coolers.
Oil cooler clogged internally.	Consult Atlas copco.
Oil filters clogged.	Replace oil filters.
Oil level too low.	Check oil level. Top up with recommended oil if necessary.
Thermostatic by-pass valve remains stuck in open position.	Remove valve and check for proper opening and closing. Replace if out of order.
Fan blade(s) broken.	Check and correct if necessary.
Oil separator element (OS) clogged.	Have element removed and inspected by an Atlas copco Service representative.

Alternator precautions

1. Never reverse the polarity of the battery or the alternator.
2. Never break any alternator or battery connections while the engine is running.
3. When recharging the battery, disconnect it from the alternator. Before using booster cables to start the engine, be sure of the polarity and connect the batteries correctly.
4. Never operate the engine without the main or voltage sensing cables connected in the circuit.

