

ED SERIES

Little hoist. Lots of power.

Plug the ED into any standard 115 V wall socket and you're ready to lift. With speeds up to 44 fpm, you'll be amazed that such a small hoist moves so quickly. Designed for productivity and portability, the ED also offers a variable-speed option to adjust the speed to best suit your application.

High-Speed Motor

The ED electric hoist is a quick-lifting, single-phase speed demon available in a variety of configurations. The compact DC motor reduces weight, generates less heat and maintains duty cycles to keep production moving.

Standard Double-Braking System

Get double the protection with a Weston-style mechanical load brake plus a regenerative brake.

Quiet, Smooth Operation

With bearings immersed in an oil bath, you can hear how smooth the ED electric hoist operates. That reduced friction results in less noise and vibration, which extends the hoist's service life.

Durable Heat-Treated Gearing

Kito's own heat-treating process increases the overall hardness and strength of internal parts for increased resistance to wear. Our three-step process of bright heat treatment, case hardening and induction imbues the ED with outstanding performance.

Integrated Friction Clutch

Integrated with the load brake, the high-performance friction clutch on the ED is engineered to protect against overwinding or overtravel, which can damage the hoist and cause downtime.



ED SERIES

CAPACITY

- 100 to 480 kilograms
- Single and dual speed

STANDARDS

- CSA approved
- ASME B30.16 Safety Standard
- ASME HST-1 Performance Standard
- IP44 environmental protection
- Load-bearing parts are only stressed to 20% of their limit at rated capacity

OPTIONS

- Dual Speed Units Available
- Plastic, canvas or steel chain containers
- Lift Lengths can be customized to suit requirements
- Hook or manual trolley mount
- TMH Mini Trolley designed to work exclusively with the ED hoist

BODY

- Die cast aluminum frame
- Low headroom profile
- Weather tight construction resists dust and water

-

GEARS

- Precision induction hardened, spur gears immersed in oil bath ensure quiet, smooth operation and long life

LOAD CHAIN

- Abrasion and corrosion resistant load chain is made from heat-treated alloy steel
- Grade 80

CHAIN GUIDE

- Long-lasting, heavy-duty cast iron construction

HOOKS

- Forged carbon steel opens gradually without fracturing under excessive loads.
- Bottom hook swivels 360 degrees
- Self-closing top and bottom hooks with heavy-duty hook latch

BEARINGS

- Heat-treated, deep-groove ball and needle bearings are immersed in an oil bath

CONTROLS

- Impact-resistant plastic push button with molded strain relief.
- Adjustable low speed on dual-speed pendant models
- Unique to Cylinder Control: In-line cylinder control permits one-handed operation
- Adjustable High/Low Speeds with easy touch-finger turn knobs for quick selection from high to low speed
- Low voltage, IP65 dust and watertight pendant control

BRAKE

- Weston-style mechanical load brake and regenerative brake

MOTOR

- Voltage: 120-1-60 volt
- Single phase
- Horse Power: .4 to .8 hp
- Duty Cycle: Varies by capacity
- Compact DC motor with rectifier for AC current
- Variable high speeds up to 44 ft/mi

OVERTRAVEL PROTECTION

- An integrated high-performance friction clutch prevents damage from overloads and overtravel
- Upper limit switch prevents overtravel

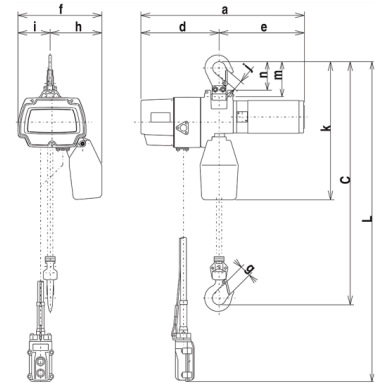

DIMENSIONS

Capacity (tonne)	Model	C	a	d	e	f	h	i	g	j	k	m	n
100 kg	EDL10S	300	371	187	184	200	120	80	27	25	340	92	73
240 kg	EDL24S	325	428	205	223	219	135	84	27	25	362	92	73
480 kg	EDL48S	520	428	205	223	229	155	74	24	24	454	149	----

SPECIFICATIONS

Capacity (tonne)	Model	Standard Lift (ft)	Max Lift (ft)	Lift Speed (ft/min)	Hoist Motor H.P.	Headroom (in)			Load Chain Falls	Rated Current (amps)		Ship Weight (lbs)	Weight per Additional 5ft of Lift (lbs)
						Hook Mount	Plain Trolley	Geared Trolley		115V			
100 kg	EDL10S	10	100	43	12	12	10.5	----	1	5		25	2
240 kg	EDL24S	10	100	44	13	13	11	----	1	10		36	2
480 kg	EDL48S	10	50	22	20.5	20.5	20.5	----	2	10		49	4

ED

115V, PORTABLE, PENDANT CONTROL

HOOK MOUNT - DUAL SPEED / HIGH SPEED

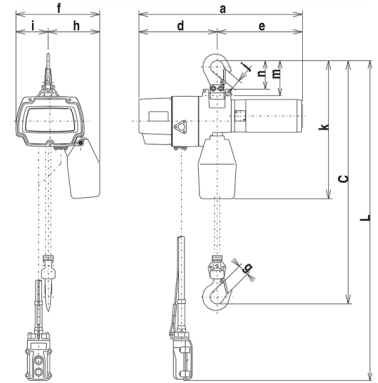

DIMENSIONS

Capacity	Model	C	a	d	e	f	h	i	g	j	k	m	n
100 kg	EDL10ST	300	371	187	184	200	120	80	27	25	340	92	73
240 kg	EDL24ST	325	428	205	223	219	135	84	27	25	362	92	73
480 kg	EDL48ST	520	428	205	223	219	155	74	24	24	454	149	----

SPECIFICATIONS

Capacity	Model	Standard Lift (ft)	Max Lift (ft)	Lift Speed (ft/min)	Hoist Motor H.P.	Headroom (in)			Load Chain Falls	Rated Current (amps)		Ship Weight (lbs)	Weight per Additional 5ft of Lift (lbs)
						Hook Mount	Plain Trolley	Geared Trolley		115V			
100 kg	EDL10ST	10	100	43/10	12	12	10.5	----	1	5		27	2
240 kg	EDL24ST	10	65	44/10	13	13	11	----	1	10		37	2
480 kg	EDL48ST	10	50	22/6.5	20.5	20.5	20.5	----	2	10		49	4