

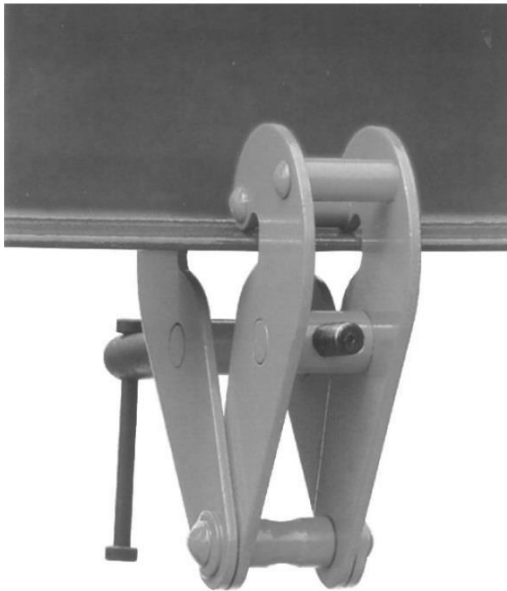

VULCAN
HOIST - PALAN

OPERATOR'S MANUAL

NBC - Nova Beam Clamp



WARNING

DO NOT INSTALL, USE OR REPAIR THIS EQUIPMENT BEFORE READING THIS MANUAL IN ITS ENTIERETY. FAILURE TO READ AND FOLLOW THE INSTRUCTIONS DESCRIBED IN THIS MANUAL COULD RESULT IN SERIOUS INJURY, DEATH AND/OR MATERIAL DAMAGES

WARNING

All persons involved in using, inspecting, maintaining or repairing this equipment must be thoroughly familiar with the contents of this manual and follow the recommended instructions and procedures to avoid injury or property damage.

WARNING

The equipment described in this manual is not designed to lift or move people nor to lift or move loads over people and must therefore not be used for such means.

WARNING

Do not use this clamp in areas containing flammable vapors, liquids, gasses or combustible dust or fibers. Do not use this clamp in highly corrosive, abrasive, wet environments or in temperatures below -10°C or above 50°C .

NOTICE

Please visit Vulcan's website www.vulcanhoist.com for the latest manual version or any other questions regarding the equipment.

Safety and Warnings

Dangerous Practices to be Avoided

DO NOT use the clamp before reading the manual

DO NOT let an unqualified person use or repair the clamp

DO NOT exceed the rated capacity of the clamp

DO NOT use the clamp to grab, secure or lift the load

DO NOT use as a “below-the-hook” lifting device

DO NOT install clamp on beams of unknown capacity

DO NOT use the clamp in temperatures below -10°C or above 50°C

DO NOT use a damaged or malfunctioning clamp

DO NOT lift people nor carry loads over people

DO NOT stay in the “fall zone” when lifting a load

DO NOT lift if the clamp is not firmly tightened on the beam

DO NOT lift unbalanced loads

DO NOT leave the load supported by the clamp unattended

DO NOT shock load

DO NOT allow a welding electrode to touch the beam clamp

DO NOT use the clamp as ground for welding

DO NOT remove or obscure labels

DO NOT use if nameplate or safety and warning labels are missing or illegible

WARNING

DO NOT use the beam clamp to grab, secure or lift the load. The beam clamp is not designed as a “below-the-hook” lifting device and must not be used as one.

Use the beam clamp to attach or suspend a load underneath a fixed, stationary and rated for that purpose beam.

WARNING

Use only Vulcan authorized replacement parts in the service and maintenance of this equipment. Failure to comply with the above limitations will void the warranty and may result in property damage, injury or death.

Installation and Operation

Operation Procedures

1	Prior to lifting, make sure the lift can be performed safely and the lift path is clear
2	Ensure the beam is of suitable capacity for the load and will not be damaged where the clamp is attached
3	Fit the beam clamp tightly on the beam and over the load's center of gravity. Make sure the clamp will not be side loaded
4	Verify that all other lifting devices are properly fastened
5	While performing the lift, do not let people to stay in or cross the "fall zone" under the clamp
6	Keep clamp parts clean and lubricated to protect against rust

Inspection

ATTENTION

The beam clamp must be inspected by the operator daily. If any deficiencies are noted, stop using the beam clamp until it is repaired or replaced.

Daily Inspection

1	Check for cracks or distortions in the structural frame, welds or mechanical components
2	Check for loose fasteners or other clamp components
3	Verify the clamping mechanism operates properly and the thread is clean, lubricated and straight
4	Check for signs of heat damage or weld splatter
5	Check for excessive wear on load bearing parts like, but not limited to: the lifting eye, the clamp mouth, the jaws, the thread, etc.
6	Make sure the nameplate and the warning labels are present and legible

ATTENTION

A qualified person must inspect regularly and in depth the clamp and its components to ensure the equipment is safe for use. These inspections may vary in frequency and detail according to the intensity of the equipment use but must include at least the daily inspection procedure.

The client is responsible for keeping dated records of all periodic inspections and maintenance procedures as means of continuously monitoring the condition of the equipment.

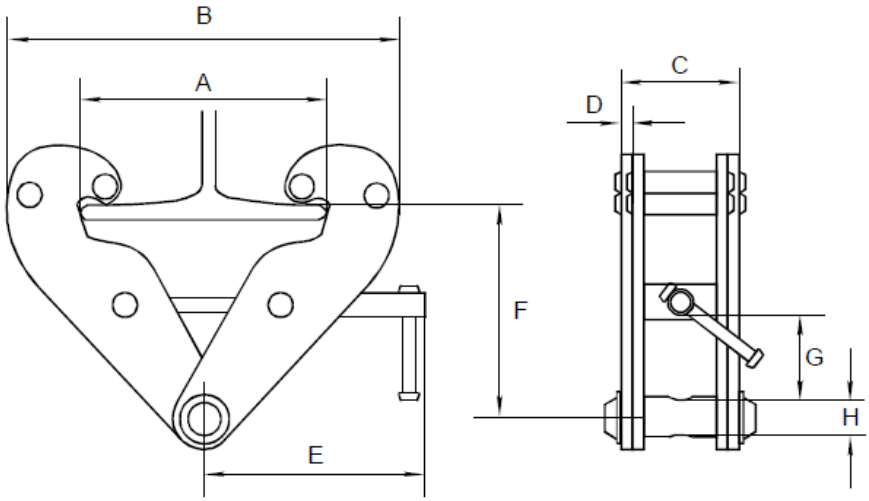

Model	NBC1T	NBC2T	NBC3T	NBC5T	NBC10T
WLL (lbs)	2200	4400	6600	11000	22000
Beam width (in)	2.95 8.66	2.95 8.66	3.15 12.60	3.15 12.60	3.54 12.60
A (in)	10.24	10.24	13.94	13.94	14.37
B (in)	7.09 14.17	7.09 14.17	9.25 19.29	9.25 19.29	12.60 19.88
C (in)	2.52	2.91	4.06	4.33	4.72
D (in)	.20	.24	.31	.39	.47
E (in)	8.46	8.46	10.24	10.24	11.02
F (in)	4.02 6.10	4.02 6.10	5.51 8.86	5.51 8.86	6.69 9.25
G (in)	.98	.98	1.77	1.77	1.97
H (in)	.87	.87	.94	1.10	1.57

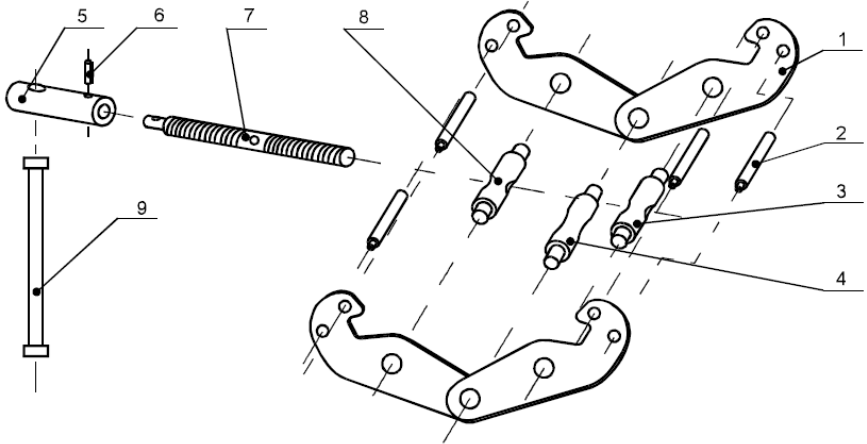

Item	Description EN	Description FR	Qty
1	Side plate	Plaque de côté	2
2	Stay	Appui	4
3	Threaded spindle support	Support de tige filetée	1
4	Equalizer pin	Arbre-égalisateur	1
5	Link cover lever handle	Manche de levier fileté	1
6	Screw	Vis	1
7	Threaded shaft	Tige filetée	1
8	Thread spindle	Écrou de tige filetée	1
9	Handle	Levier d'opération	1

BEAM CLAMP

Beam Clamp (NBC)

1T to 10T



NOVA LIFTING CLAMPS

CDE Vertical Clamp (NVC)

0.8T to 5T



Lifting Clamp (NLC)

1T to 5T



Universal Clamp (NUC)

0.8T to 5T



Horizontal Plate Clamp (NHJ)

1T to 2T



Horizontal Plate Clamp (NHP)

0.75T to 2T



Drum Lifter (NDL)

1T



* Nova lifting clamps and beam clamp have a 1-year warranty.

SUPER LIFTING CLAMPS

Screw Cam Clamp (SCC)

0.5T to 3T



Screw Cam Clamp Double Eye (SDC-S)

0.5T to 5T



Srew Cam Clamp with Universal Shackle (SUC)

0,5T à 3T



Lateral Lifting Clamp (HLC-H)

1T to 6T



Vertical Lifting Clamp (SVC-H)

0.5T to 5T



Vertical Lifting Clamp with Universal Shackle (SVC-E)

0.5T to 2T



Vertical Lifting Clamp with Remote Control (SVC-L)

0.5T to 3T



Vertical Lifting Clamp with stopper (SVC)

1T to 5T



* Super lifting clamps have a 2-year warranty.

SERVICES



RENTAL



TESTING AND
CERTIFICATION



MAINTENANCE
AND REPAIR



VULCAN HOIST - PALAN

3435, boul. Crémazie Est
Montréal (Québec) H1Z 2J2
Tel.: 514 728.4527 / Fax.: 514 374.4231
vulcanhoist.com / info@vulcanhoist.com

Authorized Distributor: