



Patent and Copyright Registered

YA LEVER HOIST

- Rounded lever design for smooth operation when placed against flat surfaces
- Grade 105 galvanized load chain, which adheres to the strict German DIN 5684 standard.
- True one touch free spooling, which automatically brakes when a load is applied.
- Redesigned hooks with tip supporting safety latch
- Hoist body has an electro-deposited black finish for corrosion resistance
- Ratchet recovery of 16.5° for 0.8t-1t and 14° for 1.6t-12t
- Internal side plates have hardened steel bushings for excellent load sheave & pinion support
- Internal side plates, pinion, pawls, and pawl springs have an electro-deposited coating that helps resist corrosion
- Internal disc hub and ratchet wheel are nickel plated for corrosion resistance
- Suitable for operation within a -20° to +130° C, -4° to +266° F temperature range



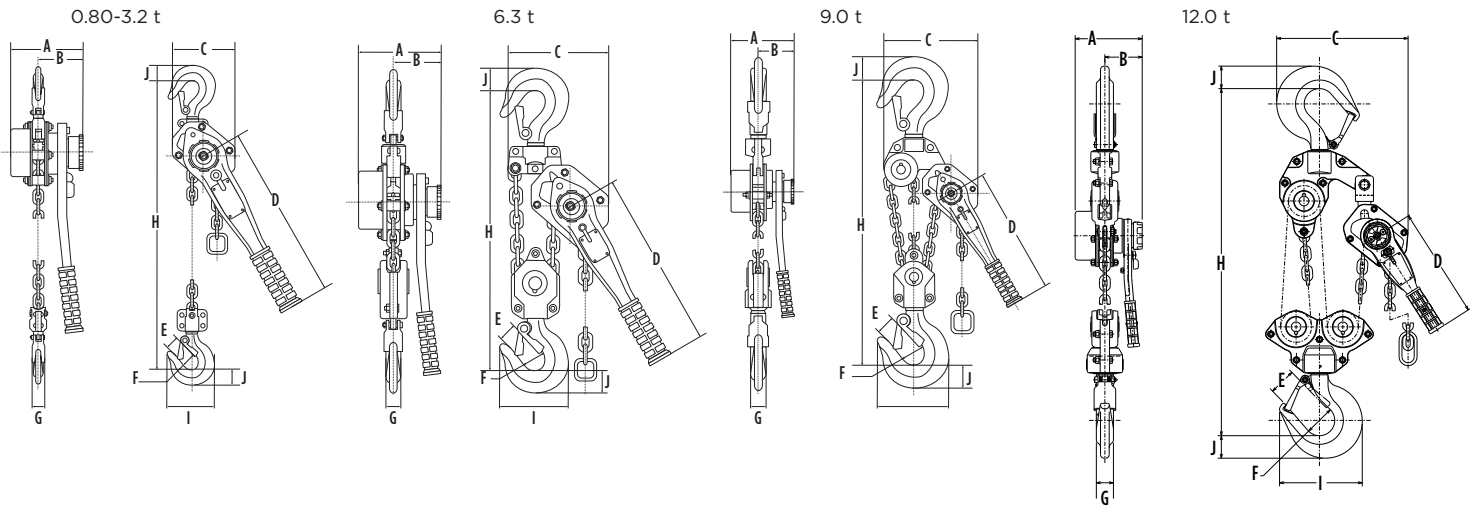

SPECIFICATIONS - YA LEVER HOIST

Model	Capacity (lbs)	Capacity (mt)	Standard Lift (ft)	Hand Effort to Lift Full Working Load (lbf)	Dia. of Load Chain (mm)	Net Weight (lbs)	Load Chain Min Breaking Load	Safety Factor
YA-80	1760	0.8	5	66	5.6	13	5.2+	6.5
YA-100	2200	1	5	82	5.6	14	5.2+	5.2
YA-160	3520	1.6	5	66	7.1	20	8.3+	5.3
YA-320	7040	3.2	5	82	9	34	13.4+	4.2
YA-630	13,860	6.3	5	84	9 x 2	59	26.8+	4.3
YA-900	19,800	9	5	86	9 x 3	93	40.2+	4.5
YA-1200	26,400	12	5	88	9 x 4	159	53.6+	4.2

*Test Load is 150% of Rated Load

DIMENSIONS (IN.) - YA LEVER HOIST

Model	A	B	C	D	E	F	G	H	I	J
YA-80	2.1	3.6	4.8	11.4	0.91	1.4	0.51	10.6	2.76	0.748
YA-100	2.1	3.6	4.8	12.3	1.1	1.7	0.59	10.6	2.91	0.866
YA-160	2.5	3.9	5.4	13.9	1.2	1.7	0.63	12.2	3.46	1.024
YA-320	3.3	4.1	7.1	16.2	1.4	2.1	0.83	12.2	3.66	1.378
YA-630	3.3	4.1	9.3	22.2	1.9	2.8	1.10	12.2	4.94	1.811
YA-900	3.3	4.1	11.8	27.1	2.9	3.4	1.87	12.2	9.06	2.461
YA-1200	3.25	4.09	14.57	31.06	2.91	3.35	1.87	12.2	9.06	2.461

* Specifications & Dimensions are subject to change without notice

