



# Submersible Pump

Model S4D1-E10

Size 4"



**PUMP SPECIFICATIONS**

- Diffuser:** G-R Hard Iron;  
Maximum Operating Pressure 108 psi (747 kPa).\*
- Impeller:** G-R Hard Iron.
- Wear Plate:** Carbon Steel ASTM A36.
- Seal Plate:** G-R Hard Iron.
- Intermediate:** Aluminum Alloy 356-T6.
- Casing:** Aluminum Alloy 6061-T6 with Chromicoat.
- Motor Housing:** Aluminum Alloy 356-T6.
- Motor Shaft:** Stainless Steel Type 416.
- Shaft Sleeve:** Stainless Steel Type 304.
- Bearings:** Upper - Open Single Row Ball Bearing.  
Lower - Two Synthetic Seals, Double Row Ball Bearing.
- Discharge Flange:** Aluminum Alloy 356-T6.
- Gaskets:** Cork with Nitrile Binder (NC710).
- O-Rings:** Buna-N.
- Wetted Hardware:** Standard Plated Steel and Stainless Steel.
- Strainer:** Urethane Coated Steel; 50.6% Open Area,  
0.375" (9,5 mm) Diameter Openings.
- Hoisting Bail:** Urethane Coated Steel.

**Standard Equipment**

**NEMA Type 3R Rainproof Control Box.** *(See Section 130, Page 90.)*  
Provides On-Off, Circuit Breaker and Motor Overload Protection.

**Optional Equipment**

- Liquid Level Control:** *(See Sec. 130, Page 150.)*
  - a. Turtle Type Pressure Activated Level Switch.
  - b. Float Activated Level Switch.

**Staging Adapter Kit.**

**MOTOR/CABLE SPECIFICATIONS**

**Motor:** Oil Filled Enclosure; 10.0 H.P.; 3450 R.P.M.; Three Phase:  
200/230/460/575 Volt, 60 Hz, 39/34/17/13.6 Full Load AMPS, 12.2 kW (Max.)

**Power Cable:**

- 200/230/460 Volt:** 6 Wire; Type GGC; 8 AWG. 3 Power Conductors,  
2 Ground Conductor and 1 Ground Check.
- 575 Volt:** 4 Wire; Type SO/SOW/SOOW; 10 AWG; 3 Power Conductors,  
Plus 1 Ground. Nominal Length 50 Feet (15 m). Standard.  
*(Specify Alternate Length at Time of Order.)*

**Recommended Generator Size:** 15 kW Across the Line Start.

\* Consult Factory for Applications Exceeding Maximum Pressure and/or Temperature Indicated.



**WARNING!**

Do not use in explosive atmosphere or for pumping volatile flammable liquids.

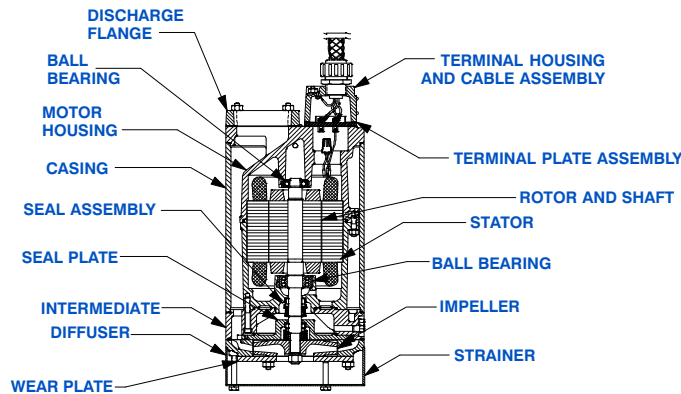
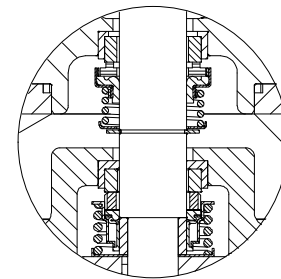

**SEAL DETAIL**

Tandem, Oil Lubricated.

**Upper Seal:** Type 21, Mechanical. Carbon Rotating Face. Ni-Resist Stationary Face. Buna-N Elastomers. Stainless Steel 18-8 Cage and Spring.

**Lower Seal:** Type 2, Mechanical. Tungsten Titanium Carbide Rotating Face and Silicon Carbide Stationary Face. Fluorocarbon Elastomers (DuPont Viton® or Equivalent). Stainless Steel 303/304 Cage and Spring. Maximum Temperature of Liquid Pumped, 122°F (50°C).\*



GORMAN-RUPP PUMPS

www.grpumps.com

Specifications Subject to Change Without Notice

Printed in U.S.A.

**Specification Data**

**SECTION 130, PAGE 900C**

APPROXIMATE  
DIMENSIONS and WEIGHTS

**NET WEIGHT:**  
**SHIPPING WEIGHT:**  
**EXPORT CRATE:**

**242 LBS. (110 KG.)**  
**257 LBS. (117 KG.)**  
**11.3 CU. FT. (0,32 CU. M.)**

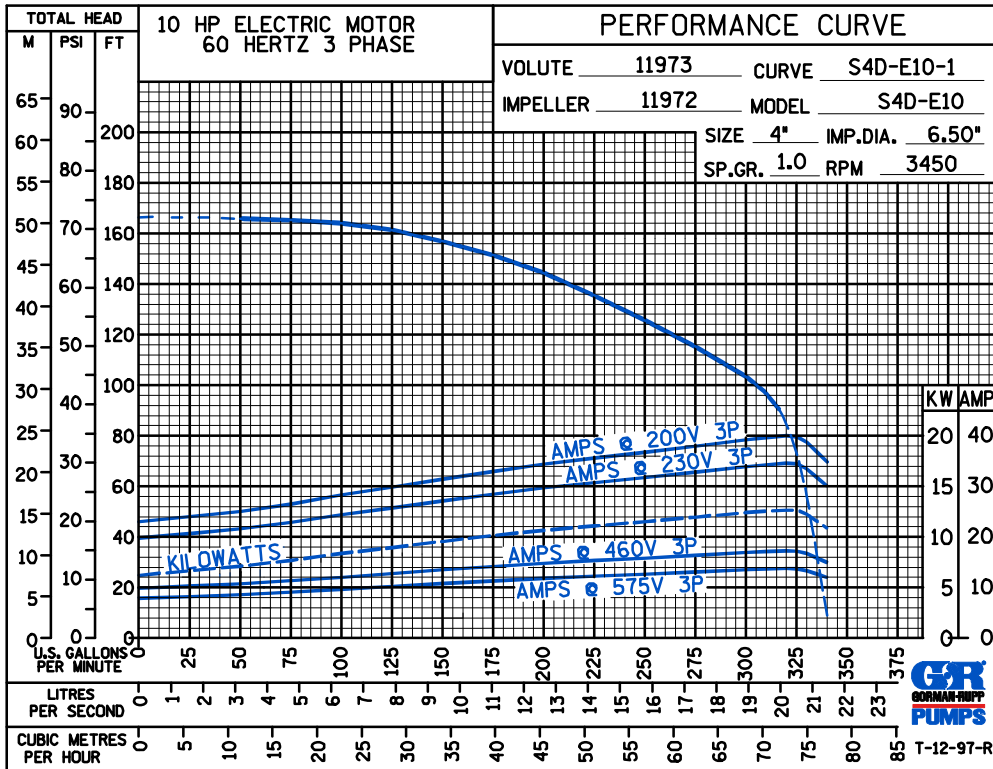
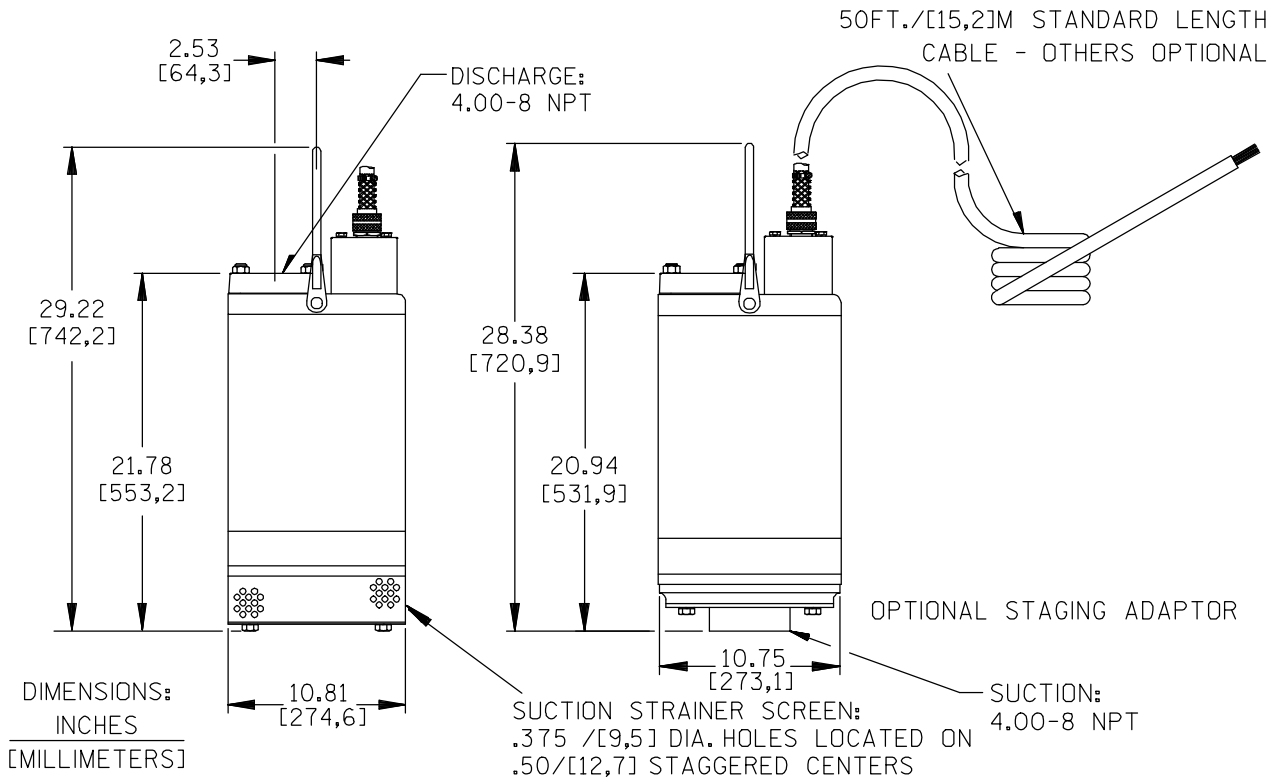

**GORMAN-RUPP PUMPS**

www.grpumps.com

Specifications Subject to Change Without Notice

Printed in U.S.A.