



Submersible Pump

Model S8B1-E100

Size 8"



PUMP SPECIFICATIONS

Diffuser: Ductile Iron 80-60-03;

Maximum Operating Pressure 165 psi (1138 Pa).*

Enclosed Type, Impeller: Ductile Iron 80-60-03.

Suction Head: Gray Iron 30.

Two Wear Rings: Copper Alloy C83600.

Motor Housing: Aluminum Alloy 356-T6.

Intermediate Bracket: Aluminum Alloy 356-T6.

Seal Plate: Gray Iron 30.

Motor Shaft: Stainless Steel 17-4 PH.

Bearings: Upper, Open, Single Row Ball Bearing.
Lower, Two Seals, Double Row Ball Bearing.

Discharge Flange: Gray Iron 30.

Gaskets: Cork with Nitrile Binder (NC710) and Vegetable Fiber.

O-Ring: Buna-N.

Wetted Hardware: Standard Plated Steel and Stainless Steel.

Strainer: Urethane Coated Steel; 48% Open Area,
0.62" (15.7 mm) Square Openings.

Hoisting Bail: Urethane Coated Steel.

Standard Equipment

NEMA Type 3R Rainproof Control Box. Provides On-Off, Circuit Breaker and Motor Overload Protection. (See Section 130, Page 100.)

Staging Adapter

Optional Equipment

Liquid Level Control: (See Sec. 130, Page 150.)

- Turtle Type Pressure Activated Level Switch.
- Float Activated Level Switch.

MOTOR/CABLE SPECIFICATIONS

Motor: Oil Filled Enclosure; 100 H.P.; 1750 R.P.M.; Three Phase: 460/575 Volt, 60 Hz, 145/108 Full Load Amps, 85 kW (Max.)

Power Cable: 6 Wire, Type GGC, 1 AWG; 3 Power Conductors, 2 Ground Conductors and 1 Ground Check. Nominal Length 50 Feet (15 m) Standard. (Specify Alternate Length at Time of Order.)

Recommended Generator Size: 200 kW Across-the-Line Start.

100 kW for Reduced Voltage Starting.

* Consult Factory for Applications Exceeding Maximum Pressure and/or Temperature Indicated.

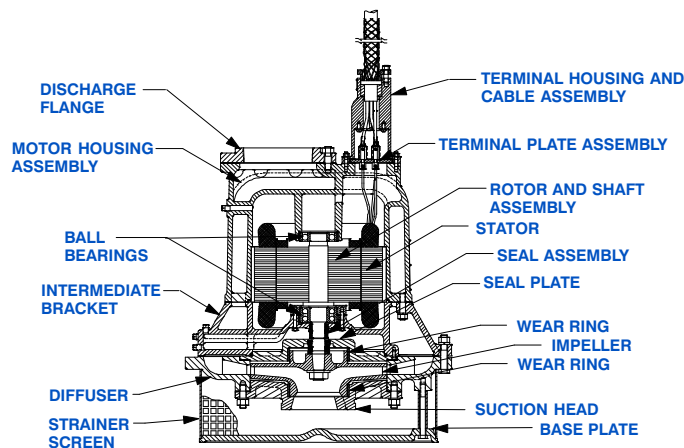
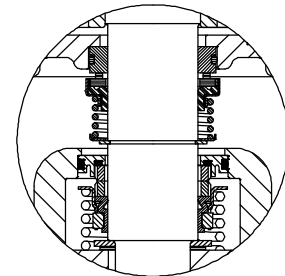

SEAL SPECIFICATIONS

Tandem, Oil Lubricated.

Upper Seal: Type 2, Mechanical. Carbon Rotating Face. Ni-Resist Stationary Face. Buna-N Elastomers. Stainless Steel 18-8 Cage and Spring.

Lower Seal: Type 2, Mechanical. Tungsten Titanium Carbide Rotating and Stationary Faces. Stainless Steel 316, Stationary Seat. Fluorocarbon Elastomers (DuPont Viton® or Equivalent). Stainless Steel 18-8 Cage and Spring. Maximum Temperature of Liquid Pumped, 122°F (50°C).*



GORMAN-RUPP PUMPS

www.grpumps.com

Specifications Subject to Change Without Notice

Printed in U.S.A.

Specification Data

SECTION 130, PAGE 1545C

APPROXIMATE
DIMENSIONS and WEIGHTS

NET WEIGHT: 1450 LBS. (657,7 KG.)

SHIPPING WEIGHT: 1495 LBS. (678,1 KG.)

EXPORT CRATE: 38 CU. FT. (1,08 CU. M.)

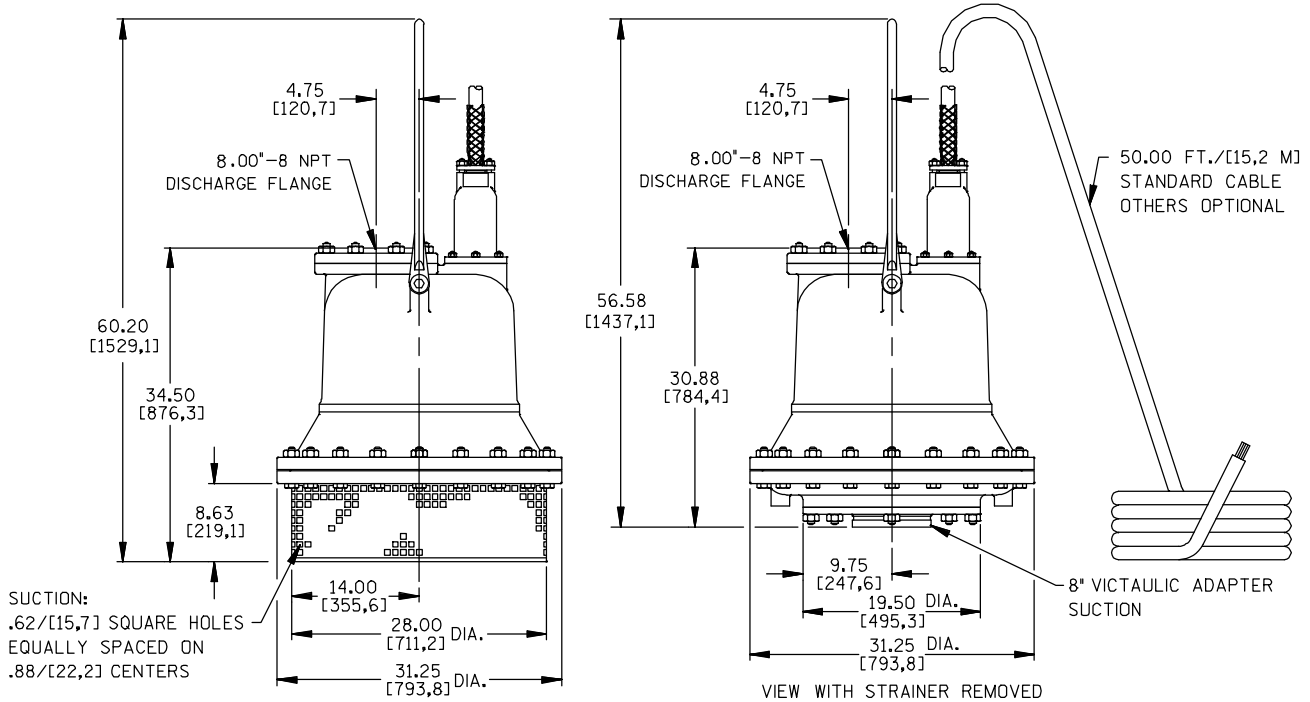

DIMENSIONS:
INCHES
[MILLIMETERS]

Victaulic is a Registered Trademark of Victaulic Company of America.

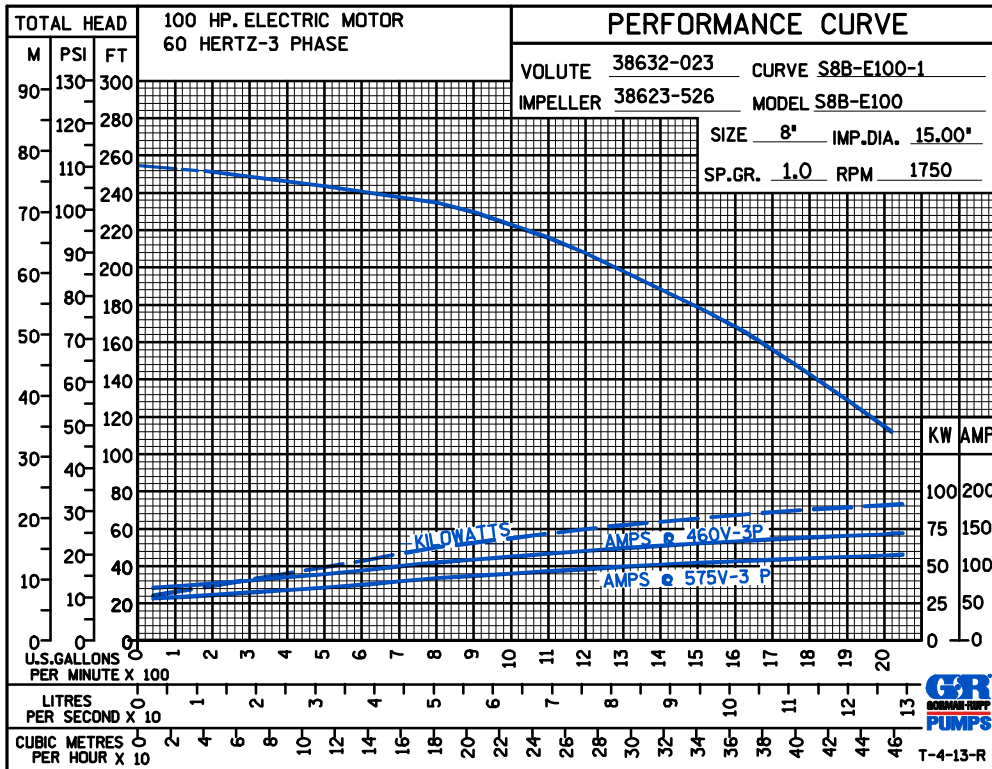

GORMAN-RUPP PUMPS

www.grpumps.com

Specifications Subject to Change Without Notice

Printed in U.S.A.